

OPERATING INSTRUCTIONS

EN

(TRANSLATION OF THE ORIGINAL OPERATING INSTRUCTIONS FR)

--	--	--	--	--	--	--	--	--	--	--

Serial No..

Fitis 120 M

Mounted reversible plough

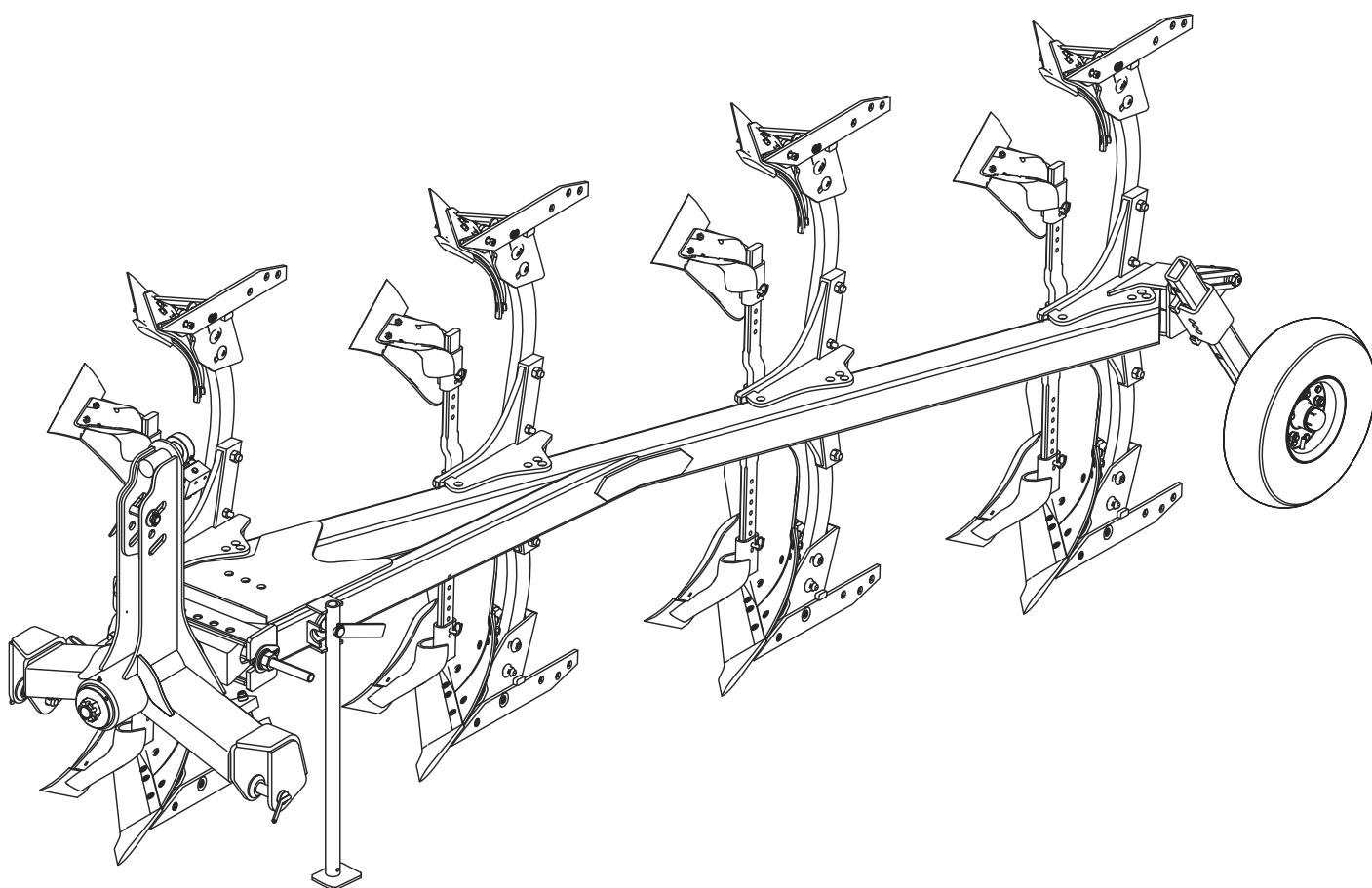

QUICK START

Fitis 120 M quick start

Preparing the tractor

1. Check the pressure of the tyres.
 - It must be identical on each side of the tractor, both at the front and back.
2. Adjust the length of the lower link arms.
 - Adjust the length of the link arms so that the hitch is perfectly horizontal for operation. The arm lengths must be adjusted so that at least 30 mm of chrome remains visible on the lifting cylinders when in operation.
3. Adjust the lateral play of the link arms.
 - Transport position: min. play (≤ 1 cm).
 - Working position: 2 to 5 cm play.

Hitch

4. Hitch the lower arms.
5. Attach the top link.
6. Make sure that there are no obstacles between the implement and the tractor.
 - There must be no possibility of the implement touching the tractor.
 - There should never be any contact between the lower arms of the tractor or the top link and the draw bar couplings of the implement when it moves from the raised position to the working position
7. Connect the hydraulic hoses
8. Transport/working positions
 - Transport position: implement raised, top link in fixed hole to prevent shocks.
 - Working position: Top link in one of the holes, higher on the implement side than on the tractor side.
9. Working width adjustment
 - Adjust the beam supports and the offset of the implement according to the wheelbase of the tractor and the desired working width.

1st pass

10. Adjust the alignment.
 - The top link must be aligned with the tractor centreline.
11. Adjust the working depth by means of the gauge wheel.

2nd pass

12. Adjust the alignment.
13. Longitudinal levelling
 - The top link must be higher on the implement side than on the tractor side and move freely within its housing when working. Adjust the tractor lifting height and the wheel height to set the implement level and obtain the desired working depth. Check the adjustment of the pressure control and the exposed chrome on the lifting cylinders (approx.: 30 mm).
14. Lateral levelling
 - The legs must be perpendicular to the ground.

Maintenance

15. Service the implement as any other agricultural equipment, follow the recommendations in the manual.

TABLE OF CONTENTS

QUICK START

INTRODUCTION

1	Instructions.....	6
1.1	Product documentation.....	6
1.2	Explanation of symbols.....	6
1.3	Regulations and legal provisions	6
1.4	Identification of your equipment.....	6
1.5	Associated documents.....	6
2	Safety instructions and rules	7
2.1	Safety instructions	7

USE

3	Description of the implement	11
3.1	General views	11
3.2	Technical specifications.....	12
3.3	Technical characteristics - solid body	12
3.4	Technical characteristics - slatted body.....	12
3.5	Dimensions and weights.....	12
3.6	Headstock RH 80.....	13
3.7	Alignment	13
3.8	Working width.....	13
3.9	Gauge wheel	13
3.10	Mould board	14
3.11	Ploughshare.....	14
3.12	Fin coulter (Optional)	14
3.13	Deflector (Optional).....	14
3.14	Safety devices	14
4	Preparing the tractor.....	15
4.1	Required tractive power	15
4.2	Tractor wheels	15
4.3	Ballasting the tractor.....	15
4.4	Length of the lifting links.....	16
4.5	Position of the stabilisers	16
4.6	Top link.....	17
5	Hitching and unhitching	17
5.1	Hitching the implement to the tractor.....	17
5.2	Unhitching the implement from the tractor.....	19
6	Hydraulic connections	19
6.1	Required hydraulic control valves.....	19
6.2	Max. hydraulic	19
6.3	Hydraulic connections.....	19

7	Preparation of the implement before work.....	20
7.1	Location of adjustment points	20
7.2	Preparing the plough bodies before ploughing.....	20
7.3	Working width adjustment.....	21
7.4	Offset adjustment	22
7.5	Alignment adjustment.....	22
7.6	Installing the sub-soiler (optional)	23
7.7	Gauge wheel adjustment.....	24
8	Changing between transport and working position.....	25
8.1	Changing to transport position	25
8.2	Driving on the road.....	25
8.3	Changing to working position.....	25
9	Field adjustments.....	26
9.1	Use in the field.....	26
9.2	First pass.....	26
9.3	Second pass	26
9.4	Adjustment of skimmers (optional)	28
9.5	Adjustment of deflector (optional).....	29
9.6	Adjusting the sub-soiler (optional)	29

MAINTENANCE

10	Protection of the environment.....	30
10.1	Soil contamination.....	30
10.2	Worn tyres.....	30
11	Cleaning	30
12	Inspection	30
12.1	Checking the hydraulic system.....	30
12.2	Lubrication and greasing.....	31
13	Troubleshooting and repair.....	32
13.1	Tripping the mechanical stone safety device - replacing the shear bolt	32
13.2	Replacing the shear bolt	32
14	Spare parts.....	34
14.1	Maintenance of plough bodies.....	34
14.2	Tightening torques	35
14.3	Precautions for storage.....	35
14.4	Returning to operation and additional check.....	36
15	CE declaration.....	37

INTRODUCTION

1 INSTRUCTIONS

1.1 Product documentation

This manual forms an integral part of the implement, and in the event of sale, it must be passed on with the implement in compliance with the applicable regulations.

- Read this manual carefully so that you understand all the information contained, ensuring completely safe operation and service. We reject any liability for damages caused by non-observance of the instructions in this manual.

1.2 Explanation of symbols

! **CAUTION:**
Risk of physical injury.
Risk of damage to the implement or to its surroundings.

⚡ **DANGER:**
Risk of electric shock.

i **IMPORTANT:**
Useful information.

1.3 Regulations and legal provisions

1.3.1 CE label

The CE label shows that the implement described in this manual complies with the following directive:

- Machinery directive (directive 2006/42/EC).

1.4 Identification of your equipment

1.4.1 Type plate

The type plate contains the following information:

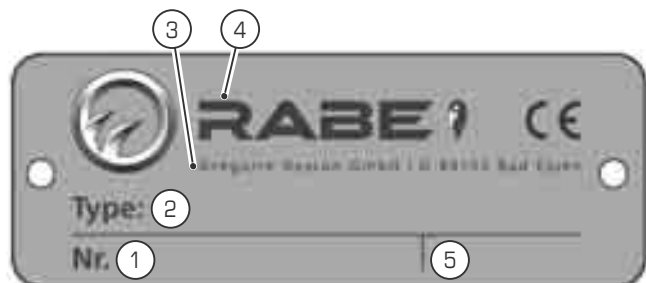

- Legend**
- 1 Implement serial number
 - 2 Model type of implement
 - 3 Address and country of manufacture
 - 4 Name of manufacturer
 - 5 Year and month of manufacture of implement

1.4.2 Location of type plate

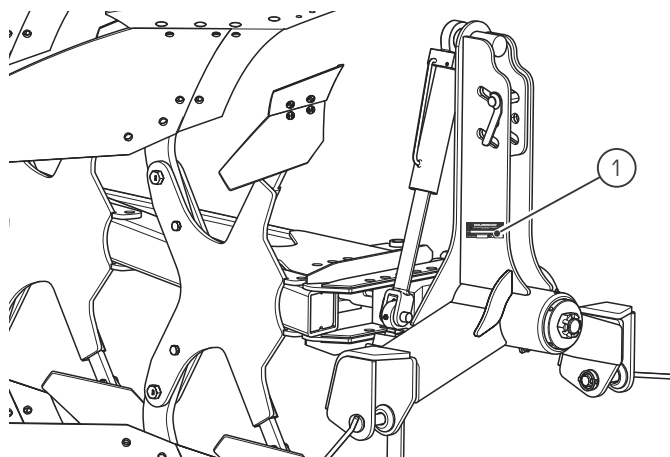

- Legend**
- 1 Type plate

1.4.3 Identification of your equipment

Please enter below the date of purchase, the model and serial number of your implement (refer to the type plate). This information will be required for all orders for replacement parts or service.

Fill out and return the registration form (4 parts) for the warranty.

Purchase date:

Model:

Serial number:

Telephone number of your agent or dealer:

Example de codes

- Fitis 120 M
 - 120: frame measure in mm
 - M: larger body clearance

1.5 Associated documents

- 1 operator's manual.
- 1 catalogue of replacement parts.

2 SAFETY INSTRUCTIONS AND RULES

2.1 Safety instructions

2.1.1 General instructions



CAUTION:

The risks of accidents during use, maintenance or repair of the implement can be reduced if you follow the safety instructions and preventative measures described in this manual.

- Only the operations and manoeuvres described in this manual may be performed. The manufacturer is not able to predict all possible situations involving risks. As a result, the safety instructions described in the manual and on the implement are not exhaustive.
- As a user, you must make reasonable allowance for possible risks to yourself, others and implement while you are using it.



CAUTION:

Non-observance of safety and usage instructions, repair or maintenance instructions for your implement can result in serious, even fatal accidents.

2.1.2 Operator qualification

- The implement may only be used, serviced or repaired by persons who are familiar with its specific characteristics and with the corresponding operational safety modes.
- Before using your implement, familiarise yourself with all the controls and with its proper operation.

2.1.3 Hitching and unhitching the implement

- If there is only one operator, then the driver himself is responsible for hitching and unhitching the implement. Use the external lift controls.
- Make sure that no-one can get between the tractor and the implement or come close to the implement during the hitching and unhitching operations.
- Before getting out of the cab to hitch or unhitch the implement, apply the parking brake, stop the engine and take out the tractor ignition key.
- Before hitching your implement, make sure that there are no signs of wear, incipient cracks or any incompatibility with your tractor on the hitching pins, draw bar hitches or the ball joints.
- Depressurise the hydraulic circuit before connecting or disconnecting the hydraulic couplings.
- Connect or disconnect the electrical connections.
- Completely lower the implement to the ground, position the support leg(s) of the implement before unhitching it. Make sure that the surface is level and sufficiently firm to ensure that the implement is perfectly stable during storage.

- If your implement is parked, make sure that it is stable to avoid the possibility of physical injury or material damage.

2.1.4 Hydraulic circuit and couplings



CAUTION:

The hydraulic circuit is subject to high pressures.

- If hydraulic fluid should escape, avoid any direct contact with the hydraulic fluid. The pressurised oil can penetrate the skin and cause fatal injuries. **Immediately consult a doctor in the event of injury.**
- Observe the order of assembly of the hydraulic couplings. Ensure that the tractor couplings are properly positioned horizontally or vertically.
- Before connecting the hydraulic circuit, clean the couplings on the tractor and implement, and check that the pressure is zero both on the tractor and implement side.
- Replace damaged or used hydraulic lines, observing the dimensional specifications.
- Prior to carrying out any work on the hydraulic system, set the implement down on the ground, depressurise the hydraulic circuit, stop the tractor engine and actuate the hydraulic valves.

2.1.5 Use of the implement

- This implement is exclusively designed for standard agricultural work. Any other use is considered to be contrary to the implement's normal use and is thus prohibited.
- Do not attempt to adjust an implement when this is in motion.
- Do not enter the pivoting range of bolted, hydraulic or mechanical locking elements.
- Wear clothing and personal protection equipment suited to the work to be performed (thick leather gloves, safety boots, protective glasses, ...).
- Create a safety perimeter for other persons.
- Do not perform any adjustment work without first having perfectly understood the required procedure.
- Use suitable tools or equipment for the work to be performed.
- Correctly use the implement and its controls, do not let untrained persons attempt to operate it.
- Do not extend the mechanical adjusting rods to avoid the risk of threads being torn or spontaneous unscrewing.
- When working alone, the operator must be in his cab and may never leave his seat. No-one may ride or stand on the implement when it is in operation.
- Stop the implement if you notice unusual noises or vibrations. Identify and eliminate the cause before resuming work.

**CAUTION:**

If the implement is equipped with a hydraulic folding mechanism, only actuate this from the tractor cab. Make sure that there is no possibility of anyone being in the pivoting zone of the side sections or of the rear accessories.

2.1.6 Transport on the public highway

- The implements must always be transported in accordance with the applicable directives and regulations relating to the prevention of accidents, road safety and occupational health.
- Before transporting the implement, ensure that the wheel studs and the fixing bolts for tandem implements (if the implement is equipped with the latter) are secure. Check the pressure and condition of the tyres:
 - Do not drive on roads with low pressures, or with damaged tyres or wheel rims.
- During road transport, use all the lighting and signal devices required by the law applicable in the country of use. If required, they can be retracted during field work to avoid any damage to them.
- The user is responsible for compliance with the applicable regulations and keeping up to date with changes.
- Regularly check the condition and fixing of the hitching pins and do not hesitate to replace them if they are worn. The tractor hitch ball joints may also show signs of wear; do not hesitate to replace them with new ones.
- Drive at a reasonable speed and in compliance with legislation so that you are always in control of the hitched assembly. Be especially careful in rough terrain or on slopes. Before starting to drive downhill, shift into low gear.
- The tractor used for transporting the implement on road must have the same weight and same power rating as that used for field work.
- Never attempt manoeuvres when anyone else is in the vicinity of the implement or the tractor.
- For implements equipped with a fold-in mechanism for transport, make sure that no persons or objects are present in the danger zone when the respective sections are being folded in.
- Observe all the common sense rules when driving, especially in bends in the road and where it is narrow.
- Take all required precautions before leaving the tractor. Apply the parking brake, stop the engine and take out the ignition key.
- It is prohibited for anyone to ride on the implement or between the implement and tractor when driving on public highways.

2.1.7 Maintenance

- The maintenance area must be clean, dry, well ventilated and well lit.
- If it is necessary to work on or remove an implement subassembly in a raised position, prop up the implement in a systematic manner by means of suitable and sufficiently strong supports.
- For repairs to components under pressure or under tension (accumulators, springs, etc.) refer to the specific procedures and equipment. Such repairs must only be performed by qualified persons.
- After the work is completed, make sure that all equipment and tools used have been removed.
- Regularly check that the wheels studs, the lower fixing nuts for wearing parts, screws and bolts are secure.
- Always use original replacement parts as only these meet the manufacturer's technical specifications.

2.1.8 Loading and unloading

- Loading and unloading with a tractor.
 - Hitch the implement to or unhitch it from the tractor before loading it onto a truck or unloading it from a truck.
 - Loading and unloading the implement: an assistant is required to guide the manoeuvres.
 - Attach or remove the transport safety devices.
- Loading and unloading with the aid of a crane.

**CAUTION:**

Only attach the lifting gear to the specified fixing points with the aid of suitable fixings. Never stand under a raised or unsecured load.

2.1.9 Safety stickers



CAUTION:

Take care not to damage the safety stickers when washing the implement.



IMPORTANT:

Replace damaged or missing stickers.

Locations of the safety stickers.

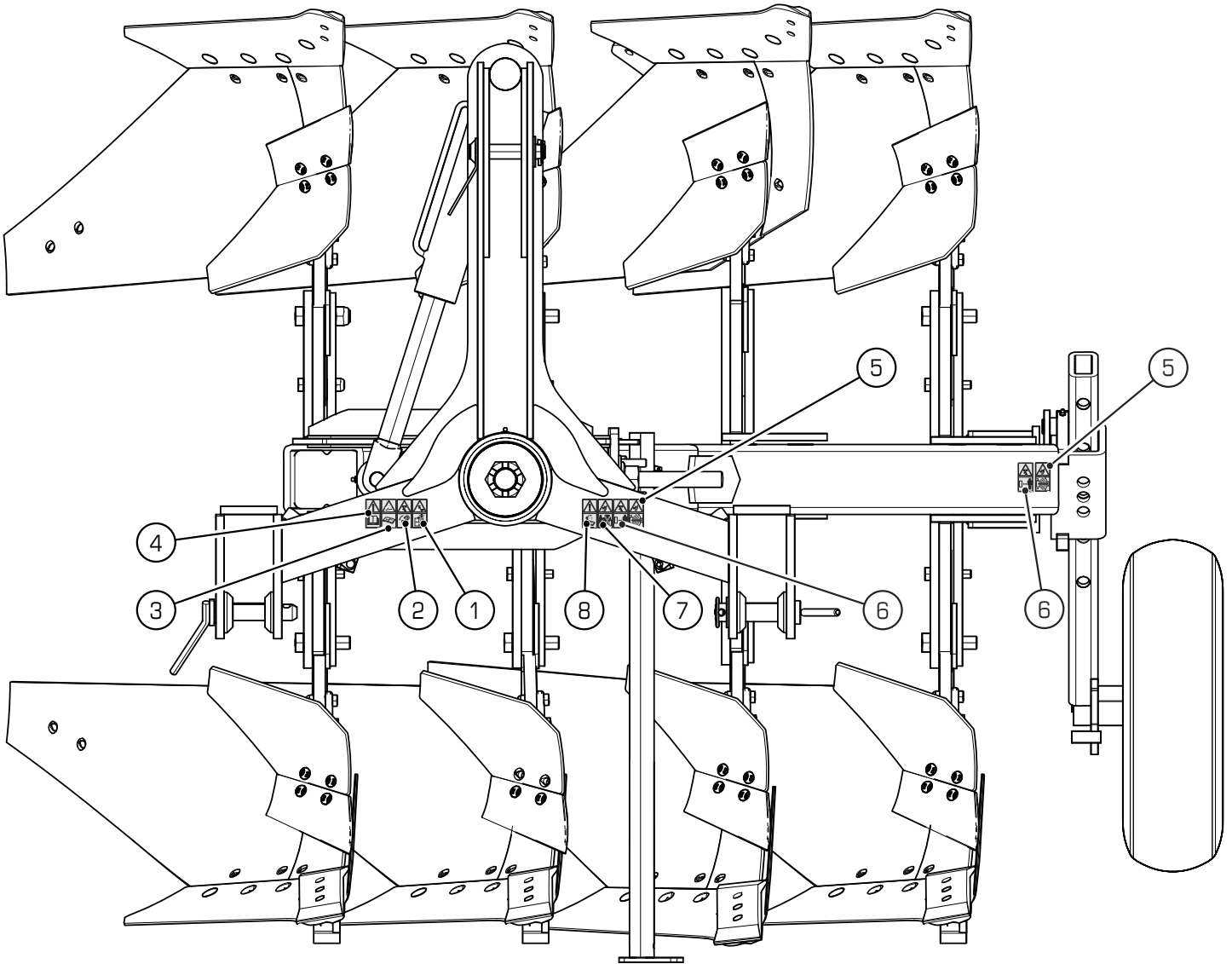









Legend

- 1 "Do not climb onto the implement" sticker
- 2 "Locking device" sticker
- 3 "Hydraulic leak" sticker
- 4 "Read the operator's manual" sticker

- 5 "Pivoting zone" sticker
- 6 "Stay outside the working zone" sticker
- 7 "Stay outside left-hand working zone" sticker
- 8 "Stop engine and remove the key" sticker

Explanation of stickers

Number	Sticker	Description
1		Do not climb onto the implement Do not transport anyone on the implement.
2		Locking device Install the locking device before carrying out any work in the danger zone.
3		Hydraulic Leak Follow the instructions of the operator's manual when performing servicing operations.
4		Read the operator's manual Read the operator's manual and the safety instructions before starting up the implement and take account of them during operation.
5		Pivoting zone Remain outside the pivoting zone.
6		Stay outside left-hand working zone Always stay out of the working area of the three-point linkage when using the remote control.
7		Stay outside left-hand working zone Always stay out of the working area of the three-point linkage when using the remote control.
8		Stop engine and remove the key Stop the engine and remove the ignition key before any maintenance or repair work.

USE

3 DESCRIPTION OF THE IMPLEMENT

3.1 General views

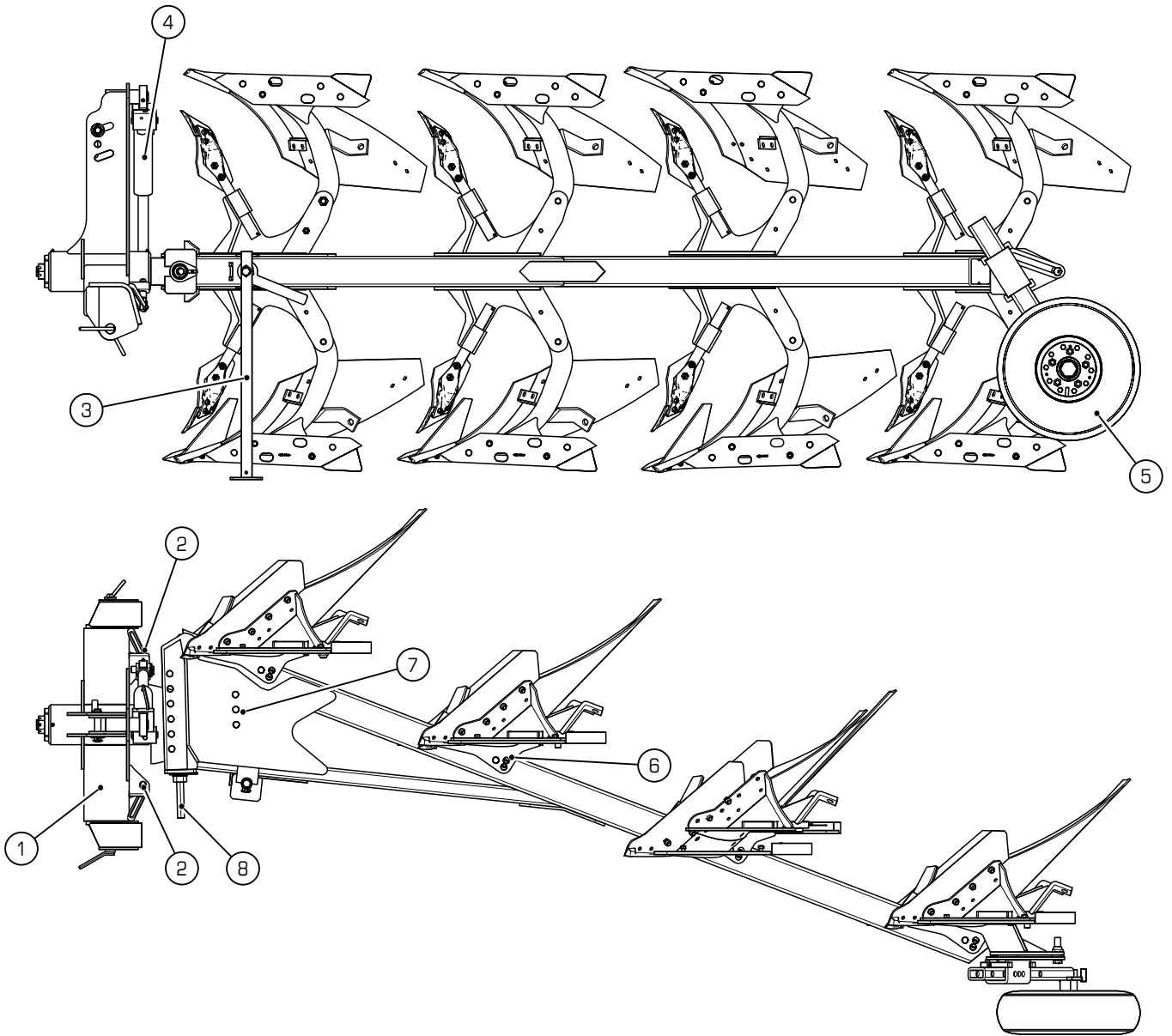

Legend

- | | |
|-------------------------|---------------------------------------|
| 1 Headstock | 5 Gauge wheel |
| 2 Angle adjustment stop | 6 Working width adjustment |
| 3 Parking support leg | 7 Offset adjustment |
| 4 Turnover cylinder | 8 Vertical alignment adjustment screw |

3.2 Technical specifications

Part	Standard equipment	Optional equipment
Headstock	<ul style="list-style-type: none"> Fixed hitch cat. II Hydraulic turnover with cylinder. Ø 80 mm shaft Tilt adjustment mechanical stop. 	
Frame	<ul style="list-style-type: none"> Beam 120 x 120 x 10 mm. 	
Working width	<ul style="list-style-type: none"> Manually adjustable from 12" to 16" (= 0.30 to 0.40 m). 	
Alignment adjustment (= tilt)	<ul style="list-style-type: none"> Screw adjustment. 	
Adjustment of the working width of the 1 st body (= offset)	<ul style="list-style-type: none"> By bolting the beam on the stub axle. 	
Inter-body clearance	<ul style="list-style-type: none"> 1.00 m (= 39") 	
Height between points	<ul style="list-style-type: none"> 1.60 m. 	
Safety systems	<ul style="list-style-type: none"> Lightweight bolt (C). 	
Hydraulic	<ul style="list-style-type: none"> 1 DA direct connection to tractor. 	
Gauge wheel	<ul style="list-style-type: none"> Single height-adjustable wheel. 600 x 8 tyre 	
Bodies	<ul style="list-style-type: none"> One-piece shares or detachable point blade. 	<ul style="list-style-type: none"> Slatted mouldboards
Skimmers	<ul style="list-style-type: none"> Height adjustable 	

3.3 Technical characteristics - solid body

Body designation	max. working depth approx. cm	Working width to approx. cm	Weight kg	Description
BP-322 P	38	50	56	One-part ploughshare, comprising a reversible point or a hard coating

3.4 Technical characteristics - slatted body

Body designation	max. working depth approx. cm	Working width to approx. cm	Weight kg	Description
BP-330(331) WS	30	45	35	One-part ploughshare, comprising a reversible point or a hard coating

3.5 Dimensions and weights

i IMPORTANT:
The implement dimensions and weights are provided for information purposes; they may vary according to options and equipment.

i IMPORTANT:
After use, the weight of the implement may be increased by the accumulation of soil or residues.

Number of bodies	Overall width (m)	Working width (" and m)		Weight with safety C (kg)
3	3.40	12" to 16" 0.30 to 0.40 m	0.90 to 1.20	920
4	4.40		1.20 to 1.60	1,070

3.6 Headstock RH 80

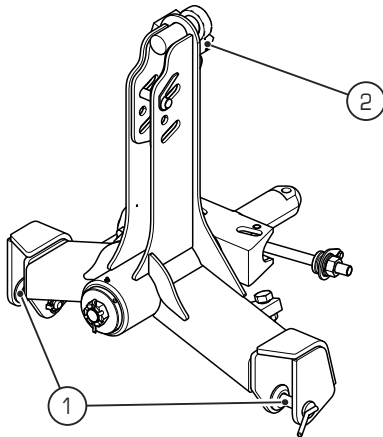

Legend

- 1 Hitch pins
- 2 Turnover cylinder

The implement is equipped with a Ø80 mm shaft, mounted on two tapered roller bearings of the same diameter.

3.6.1 Hydraulic turnover

The implement is turned-over by means of a hydraulic cylinder (2) operated from inside the tractor cab.

3.7 Alignment

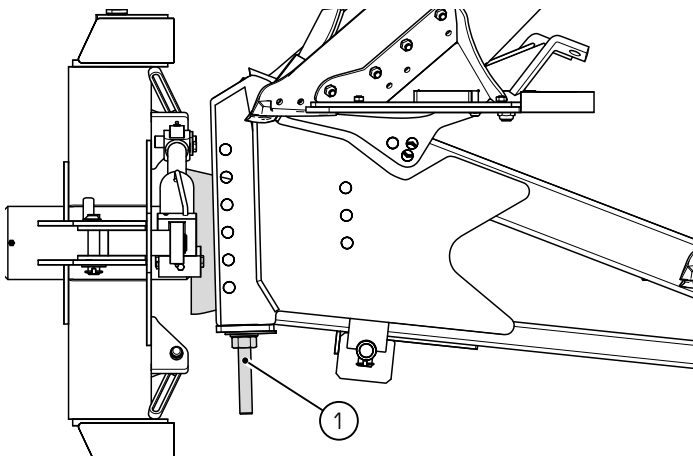

Orients the implement to align it with the tractor. Reduces unnecessary lateral forces, makes the implement easier to pull and improves the quality of ploughing.

3.8 Working width

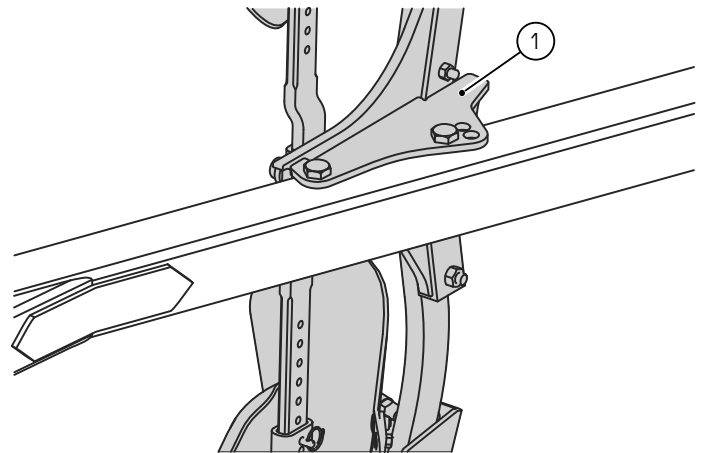

Legend

- 1 Plough body working width adjustment

The working width of the bodies can be set to three positions: 12", 14 or 16" (0.30 to 0.40 m per body).

3.9 Gauge wheel

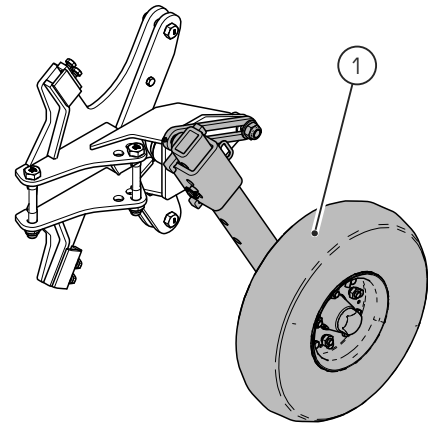

Legend

- 1 Gauge wheel

The gauge wheel (1) controls the working depth of the rear of the implement.

3.10 Mould board

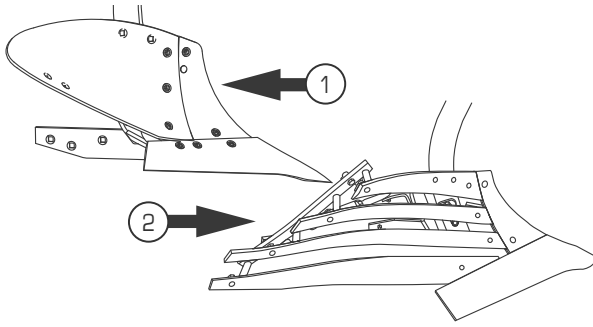

- Legend**
1 Solid body
2 Slatted body

The mould boards of the implement are:

- Solid.
- Slatted.
 The slatted versions are intended to be used in sticky ground conditions.

3.11 Ploughshare

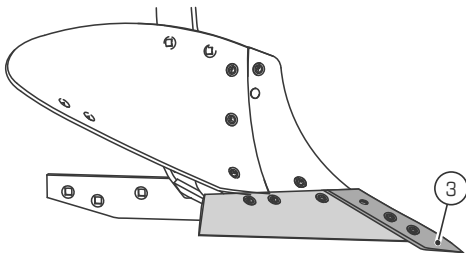

- Legend**
3 Reversible point

The ploughshares have a replaceable, reversible point.

3.12 Fin coulter (Optional)

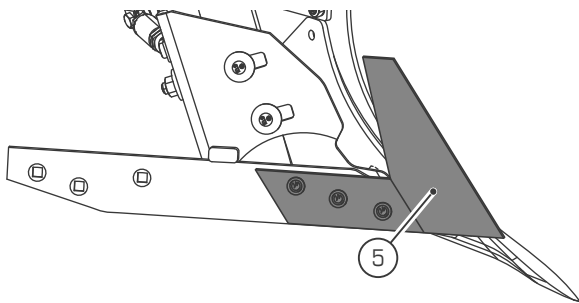

- Legend**
5 Fin coulter

The fin ensures a clean cut furrow and protects the front edge of the implement's mouldboard.

3.13 Deflector (Optional)

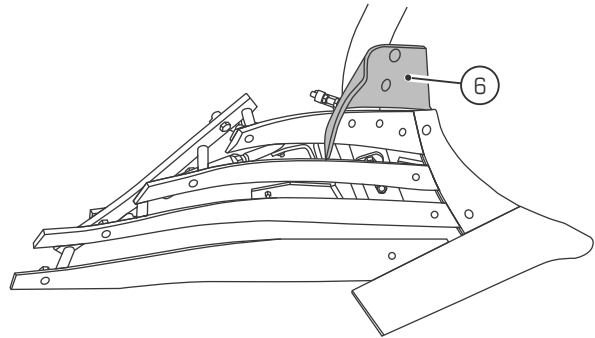

- Legend**
6 Deflector

The deflector improves the turning of the soil.

3.14 Mechanical safety device

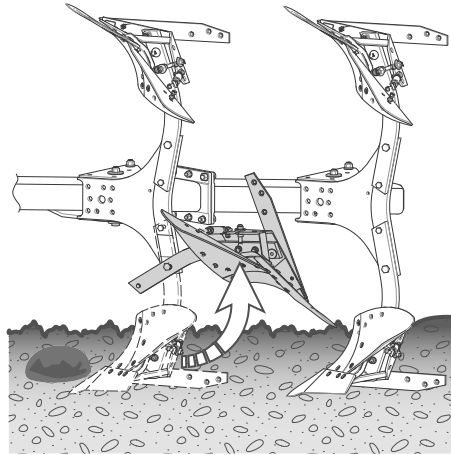

A shear bolt protects against any risk of damage to the link arm and the body of the implement.

In the event of overload, the body of the plough avoids the obstacle by shearing of the bolt.

The sub-soiler is also protected against any risk of damage by the shear bolts.

4 PREPARING THE TRACTOR

4.1 Required tractive power

The power required to tow your implement varies according to the soil texture, the working conditions and the tractor equipment (tyres, front ballast, etc.).

The following technical specifications are provided as a guide. For additional information, consult your dealer.

Number of bodies	Power
3	75 Hp
4	100 Hp

4.2 Tractor wheels

4.2.1 Tractor tyres

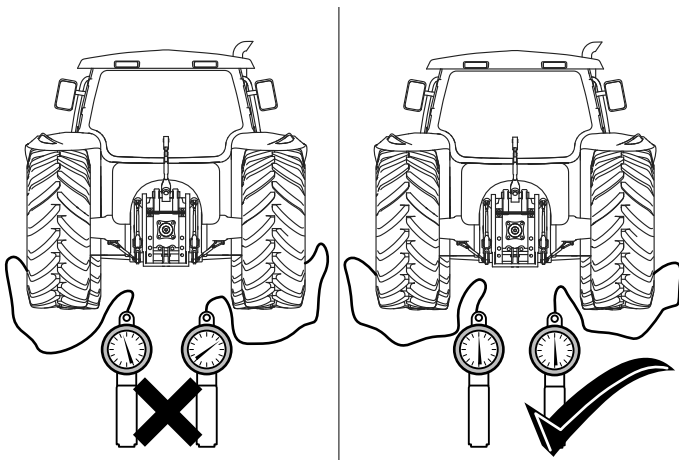

Check the general condition and the pressure of the tractor tyres (refer to the tractor operator's manual). The pressure must be identical on both sides of the tractor to ensure that the implement is level.

i IMPORTANT:
Inflate the tyres to the pressures specified by the manufacturer.

4.2.2 Tyre spacing

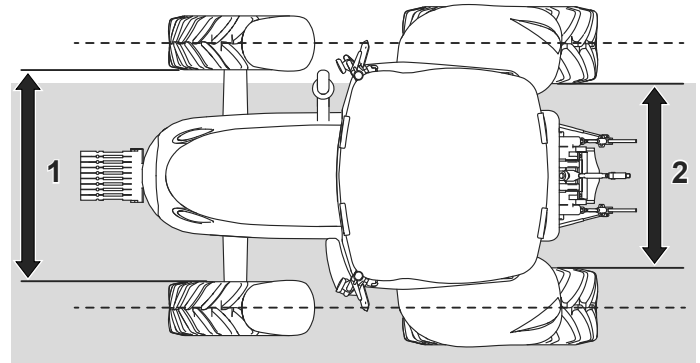

Legend

- 1 Front tyre spacing
- 2 Rear tyre spacing

If the implement has a large number plough share pairs, the wider the tractor's track, the better the tractor/implement combination will perform.

To guide the tractor in the furrow, align the middle of the front axle with the middle of the rear axle. You will thus avoid friction of the front wheel on the ploughing face.

The offset adjusting cylinder or the offset mechanical arm (width of the 1st furrow) enables the adjustment of the implement to the tractor.

The adjustment of the distance between tyres depends on the working width of each body and the length of the offset arm. On sloping ground, a large distance between tyres gives good stability to the tractor/implement combination.

Distance between rear tyres (2):

- min.: 1.30 m
- max.: 1.60 m

4.3 Ballasting the tractor

The implements hitched to the front and rear of the tractor may not exceed the total permissible load, the permissible axle loads and the tyre specifications.

It is essential that the tractor's front axle is able to support at least 20% of the tractor's dead weight. If necessary, ballast your tractor.

Before driving on the road, always make sure that the tractor is not overloaded and that it is suitable for the hitched implement.

- Specifications for calculation:

i IMPORTANT:
Weights are stated in kilograms (kg), lengths in metres (m).

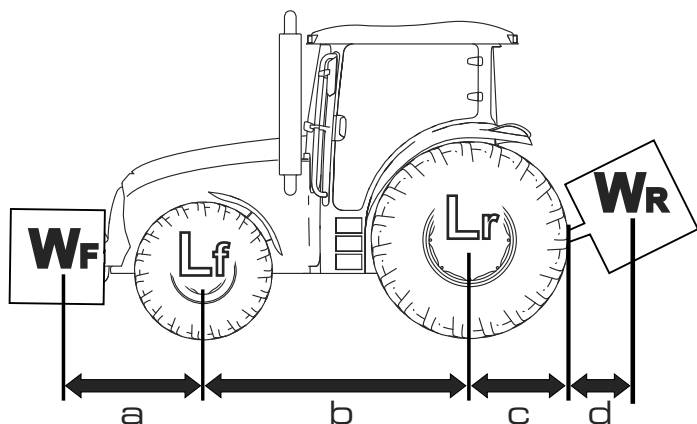

- Legend**
- We** Tractor dead weight
 - Lf** Front lifting capacity of unladen tractor
 - Lr** Rear lifting capacity of unladen tractor
 - Wf** Total weight of tractor and equipment hitched to front
 - Wr** Total weight of tractor and equipment hitched to rear
 - a** Distance between centre of gravity of front-mounted implement and the front bearing axle
 - b** Tractor wheelbase
 - c** Distance from the centre of the rear axle to the centre of the draw bar
 - d** Distance between the centre of the draw bar and the centre of gravity of the hitched implement
 - x** Manufacturer specifications for tractor for minimum rear ballasting. If no weights specified, apply a coefficient of 0.45

Formulae and calculation method

- The method of calculation of the minimum front ballast for a tool hitched to the rear: enter the result in the table.
- Method of calculating the minimum rear ballast for a heavy tool hitched to the front: enter the result in the table.
- Description of load acting on the axle: enter the value for the effective load on the front axle and the permissible weight obtained from the tractor operator's manual.
- Calculate the total actual weight: enter the value for the effective total weight and the permissible weight obtained from the tractor operator's manual.
- Calculating the effective load on the rear axle: enter the value for the effective load on the rear axle and the permissible load on the rear axle obtained from the tractor operator's manual.

	Actual values	Permissible values	Values x2 the permissible capacity of the tyres
Min. ballasting Front/Rear	Kg		
Total weight	Kg ≤	Kg	
Front lifting capacity	Kg ≤	Kg ≤	Kg
Rear lifting capacity	Kg ≤	Kg ≤	Kg

The results must be lower than or equal to the permissible values.

4.4 Length of the lifting links

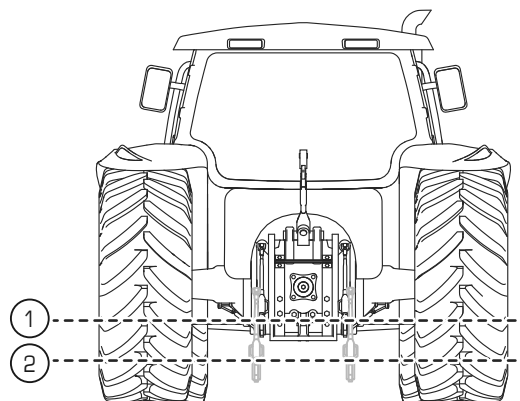

- Legend**
- 1** Raised position
 - 2** Lowered position

The length of the link arms determines the vertical alignment of the hitch and the position of the lifting cylinders while working.

- Adjust the length of the link arms so that the hitch is perfectly horizontal for operation.
- Adjust the length of the links so that in the working position at least 30 mm of lifting cylinder travel remains. This allows the amplitude of the hitch height to be adjusted from the driver's cab and the tractor's slip control device to be correctly operated (draft control).

4.5 Position of the stabilisers

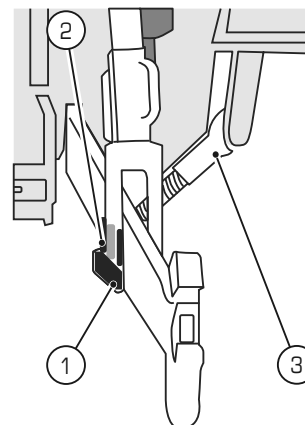

- Legend**
- 1** Operating clearance
 - 2** Pins
 - 3** Tie rod

When hitching a carried implement, the tie-rods or stabiliser shims should be positioned so that:

- In the transport position, the link arms have a minimum clearance (≤ 1 cm). This avoids any risk of impacts between the implement and the tractor during manoeuvres and transport,
- In the working position, the link arms have a clearance of 2 to 5 cm.

If necessary, obtain shim bushings to prevent the arms sliding sideways on the hitching pins. Make sure that the hitching pins are suitable for the hitch type (length and diam)..



IMPORTANT:

Grease and remove rust etc. from stabiliser bolts and threads (rods or shims) before hitching the implement to the tractor. The horizontal axles (3) of the links must be fixed to avoid any undesired or unanticipated potentially dangerous play.

4.6 Top link.

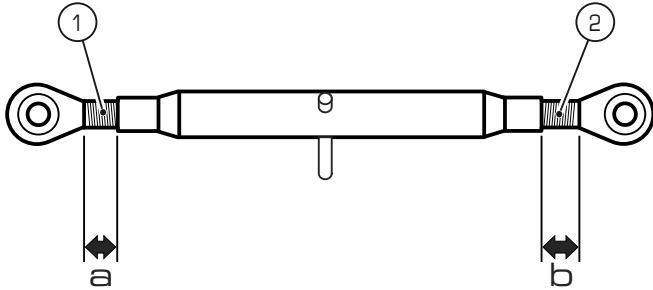

Legend

- 1 Length A
- 2 Length B

Before hitching the implement, make sure that the thread lengths (1 and 2) on each side of the top link are identical.



IMPORTANT:

Excess grease inside the top link can block the link bar. Remove the lubricating nipple and remove the excess grease.



CAUTION:

Use a ball joint to connect the top link at the implement end.



CAUTION:

Do not use automatic hooks.

- The size and shape of the hook jaw varies according to the manufacturers and models, which may, in some cases, result in a risk of interaction with draw bar yokes.
- The automatic spring latch may cause blocking in rotation of the ball joint that can cause it to become worn or to fail. This phenomenon is accentuated on Cat. III hitches: the larger the diameter of the pin, the smaller the amount of material for the lower ball joint, which makes it less resistant.



Legend

- 1 Ball joint
- 2 Automatic hook

5 HITCHING AND UNHITCHING

5.1 Hitching the implement to the tractor



CAUTION:

Make sure that hitching the implement does not result in:

- **Overloading:**
Observe the maximum permissible load at the hitching points.
- **Poor distribution of loads:**
Ballast the tractor at the front (see § 4.3).

5.1.1 Tractor equipped with link arms with fixed ball joints



IMPORTANT:

Ensure that the ball joint diameters (tractor-side) and the implement pins are compatible.

- Remove the implement hitching pins by first removing the safety bolts.
- Back up the tractor and align the ball joints on the lower link arms and the corresponding holes on the implement side.
- Insert the pins and lock them with the safety bolts.
- If the holes are difficult to align: release the telescopic arms (see tractor operator's manual), once the pins are correctly positioned and locked, back up the tractor until the telescopic arms return to their correct position and relock themselves. Check that the mechanism has re-engaged.
- Proceed with attachment of the top link.

5.1.2 Tractor equipped with link arms with removable ball joints

- Remove the hitching pins by taking out the safety bolts.
- Take out the removable ball joints of the quick-action hitching jaws of the tractor's lower link arms.
- Check the correspondence between the diameters of the ball joints and of the pins.
- Place the ball joints on the pins. Put the pins back onto the implement, not forgetting the safety bolts.
- Back up the tractor until the quick-action hitching jaws of the lower link arms are under the pins (with the ball joints fitted) of the implement.
- Raise the lifting mechanism until the jaws fit around the ball joints.
- Raise the implement about 5 cm above the ground and check the positioning of the ball joint locking mechanism in the jaws.
- Proceed with attachment of the top link.



CAUTION:

Before proceeding to connect the top link, make sure the space between the implement yoke and the lower arms of the tractor is sufficient, so that there is no possibility of contact between the raised position and the working position. A second check must be performed in the field, when the implement is under actual working conditions.



IMPORTANT:

If the coupling head is not horizontal, adjust it with the turnover cylinder. This will facilitate the hitching procedure.

5.1.3 Hitching the top link

The connection between the top link and the implement must be made by means of a ball joint (see § 4.6).

Once the lower tractor arms are hitched, check that the hitch pin is in good condition and that it matches the diameter of the ball joint and connect the top link in one of the three holes in the yoke.

Raise the implement as high as possible and make sure there is no collision with the tractor. The length adjustment of the top link and the selection of the hole are done in the field.

Position the stand in working mode: remove the lynch pin and rotate the stand to bring it into a horizontal position along the outer arm of the parallelogram. Do not forget to put back the lynch pin.

5.1.4 Hydraulic connections

- See chapter "6 Hydraulic connections", page 19.

5.1.5 Folding up the support leg

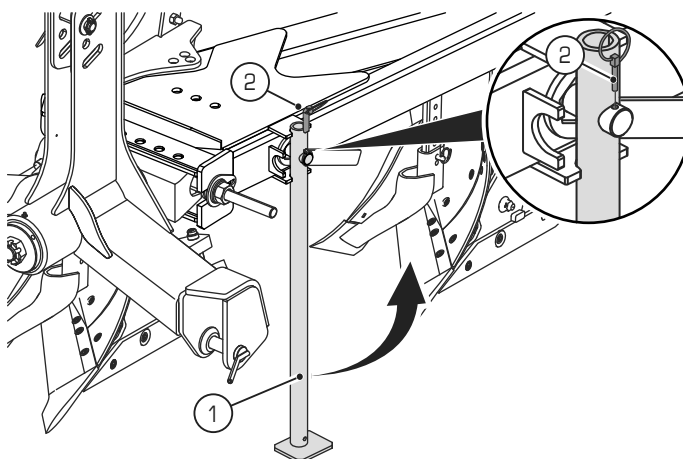

Legend

- 1 Support leg
- 2 Lynch pin

- Raise the implement using your tractor's lifting mechanism, until the support leg (1) is lifted off the ground.
- Remove the safety pin (2).
- Turn up the stand into the location provided for this purpose.

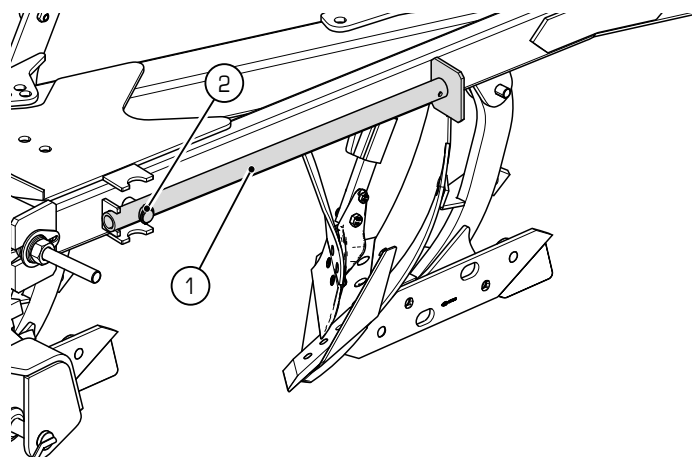

- Refit the safety pin (2).
- Proceed in reverse order to fold down the support leg.

5.2 Unhitching the implement from the tractor



CAUTION:

Before unhitching your implement, make sure the locking pin is properly locked.



CAUTION:

Make sure that there is no-one in the vicinity of the implement before lowering it.



IMPORTANT:

Before detaching the implement, make sure that the ground is sufficiently level and firm. On moist ground, place wooden blocks to wedge the components and the support leg.

- Proceed in reverse order to attachment to detach the implement:
- Place the implement in the working position, it should rest on its left-hand or right-hand plough bodies.
- Fold out the support leg.
- Place the elements vertically using the turnover cylinder, the headstock must be horizontal, this will simplify the operation.
- Lower the implement to the ground.
- Detach the top link.
- Disconnect the tractor power socket.
- Depressurise the hydraulic circuit, disconnect the hydraulic couplers and the function selector (according to options and configurations, store it away in a dry place)
- Unhook the lower link arms.

6 HYDRAULIC CONNECTIONS

6.1 Required hydraulic control valves

- 1 double-acting (DA) for turning over.



IMPORTANT:

Pressurised oil may remain in a closed circuit. Return to reservoir allows evacuation of residual pressure.

6.2 Max. hydraulic

Check the service pressure of the tractor's hydraulic system.
Max. pressure: 200 bar / 20 MPa.

- When connecting, ensure that the hydraulic couplings are correctly positioned to avoid any risk of hydraulic fluid escaping.

6.3 Hydraulic connections

- Clean the couplings on the implement and the tractor before connecting the hydraulic circuits.
- Check that the hydraulic couplings of the implement are compatible with those of the tractor.



IMPORTANT:

Check the length of the hose lines; they must not be too short (risk of rupture or tearing), nor too long (trapping or pinching of the hose in the mechanical joints, wheels, etc.).

7 PREPARATION OF THE IMPLEMENT BEFORE WORK

7.1 Location of adjustment points

- Locate the various adjustment points.
- Make sure that they are functioning properly and that they are well lubricated. Perform the checks before setting out for the fields.

E.g.: 4-furrow Prima

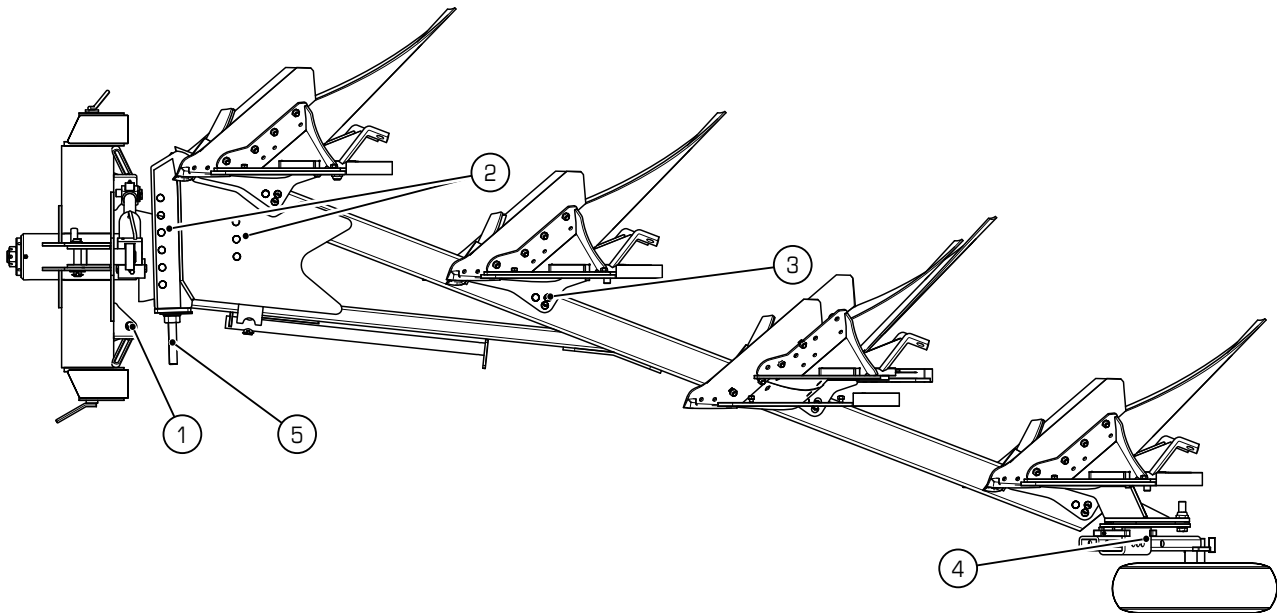

Legend

- 1 Angle adjustment stop
- 2 Offset adjustment
- 3 Plough body working width adjustment
- 4 Gauge wheel height adjustment
- 5 Alignment adjustment screw

7.2 Preparing the plough bodies before ploughing

The bodies are protected against corrosion in the factory. Before first use, remove the protective coating otherwise the soil may stick and not slide on the mould boards.

Use a paint stripper to facilitate/speed up polishing of the mould boards.



IMPORTANT:

Only use paint strippers in aerated and ventilated areas.

7.3 Working width adjustment

The working width of each body has three width settings 12", 14" or 16" (30, 35 or 40 cm).

Adjustment

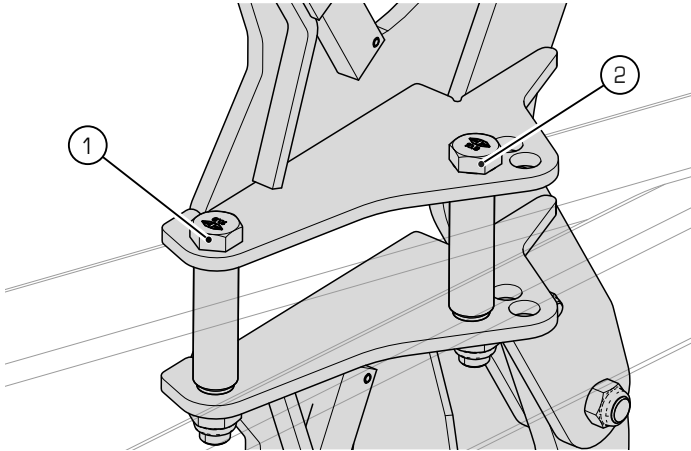

- Legend**
- 1 Pivot bolt
 - 2 Locating bolt

Adjustment

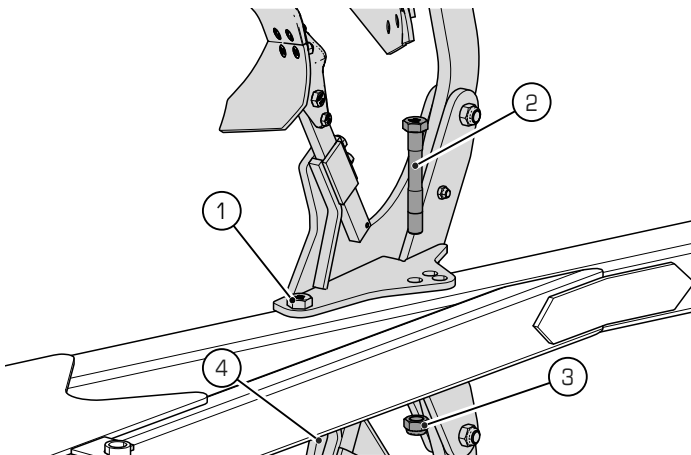

- Legend**
- 1 Pivot bolt
 - 2 Bolt
 - 3 Nut
 - 4 Nut (hidden in illustration)

- Raise the implement completely off the ground.
- Remove the nut (3) and the bolt (2).
- Loosen the nut (4).
- Turn to the desired position (12", 14" or 16").

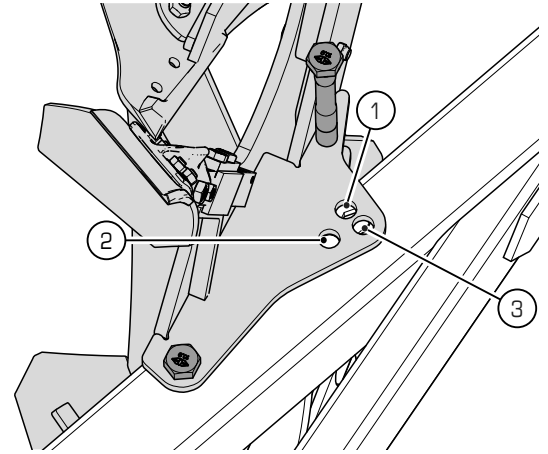

- Legend**
- 1 12" position
 - 2 14" position
 - 3 16" position

- Once in position, refit the bolt (2) and the nut (3).
- Re-tighten the nut (4).

7.4 Offset adjustment

The offset is adjusted by position of the beam on the stub axle. There are three possible positions (see illustration).

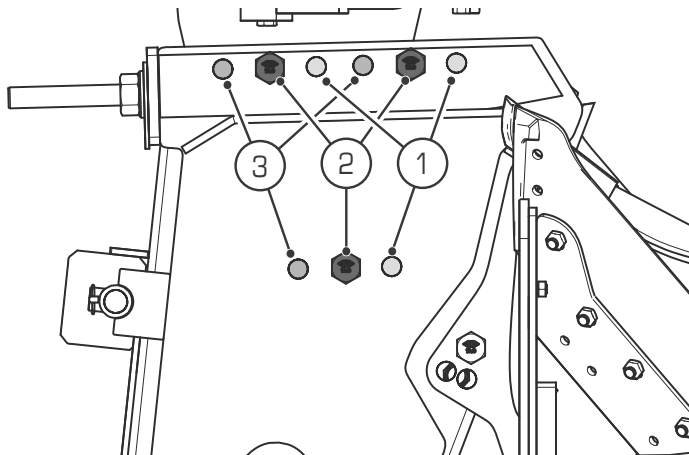

- Legend**
- 1 Setting 1
 - 2 Setting 2
 - 3 Setting 3

Working width	Setting 1 (mm)	Setting 2 (mm)	Setting 3 (mm)
12"	934	1,054	1,174
14"	1,044	1,164	1,284
16"	1,153	1,273	1,383

The table shows the correspondence between the working width of the bodies, the offset setting and the tractor wheelbase (y).

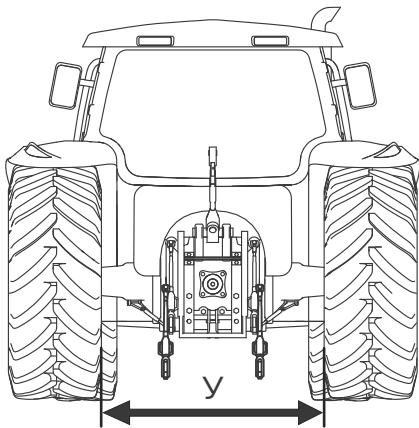

Adjustment

- Remove the three adjusting bolts.
- Move the beam to the desired position.
- Refit the adjusting bolts.

7.5 Alignment adjustment

Principle

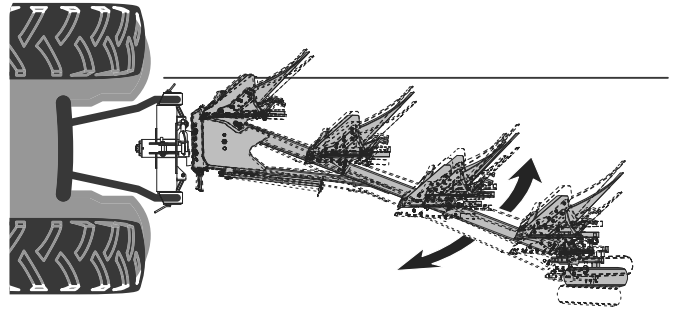

- Legend**
- 1 Alignment adjustment

Alignment adjustment orients the implement relative to the tractor.

This adjustment pivots the frame so as to align the bodies of the implement with the direction of forward movement of the tractor. This minimises unnecessary lateral forces, helps to guide the implement and optimises the quality of ploughing.

Adjustment

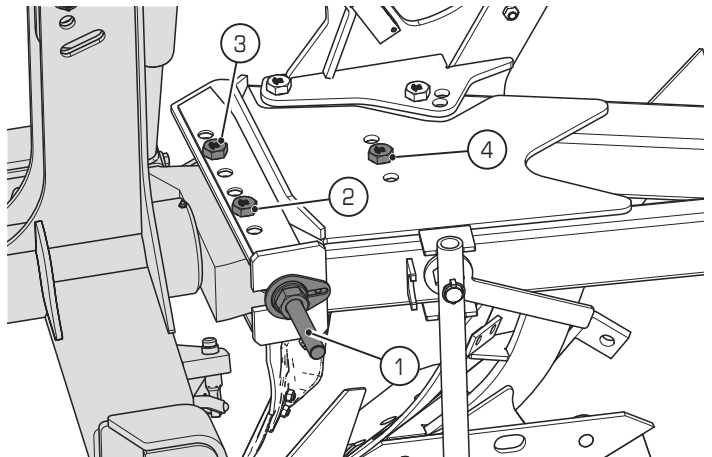

- Legend**
- 1 Adjusting screw
 - 2 Bolt
 - 3 Bolt
 - 4 Bolt

- Loosen the bolts (2, 3 and 4).
- Adjust by means of the screw (1).
- Tighten the bolts (2, 3 and 4).
- Perform a test.

Check during ploughing that the top link is in line behind the tractor. If not, re-adjust the alignment.

7.6 Installing the sub-soiler (optional)



DANGER:

Risk of accidents when using the implement for farming operations. Always follow the safety instructions given in the original operator's manual.



CAUTION:

Risk of injury through crushing when installing equipment items and making adjustments. Ensure that the implement is securely stabilised and perfectly immobilised when carrying out work.

When placing the sub-soilers in the working position, the implement must be prepared prior to operation.

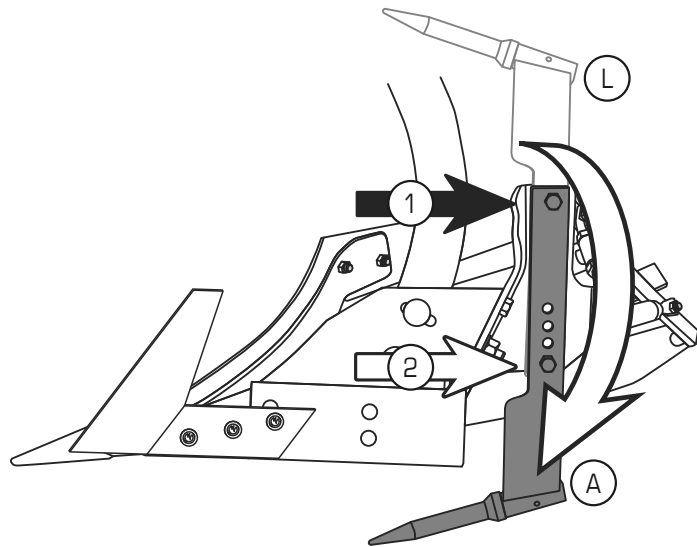

Legend

- 1 Pivot bolt
- 2 Shear bolt

Prior to working, the sub-soilers must be moved from the rest position (L) to the working position (A).



COMMENT:

Ensure that the shear bolt is correctly positioned in the right direction (2).

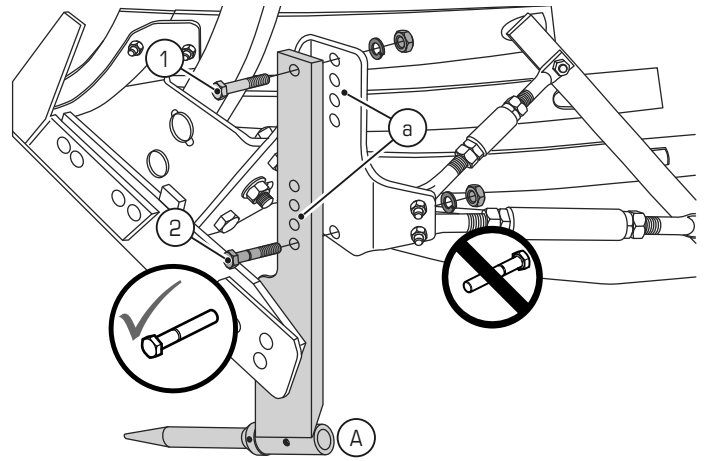

Legend

- 1 Pivot bolt
- 2 Shear bolt
- a Location of bolts
- A Working position

Adjustment

- Remove the pivot bolt (1) and the shear bolt (2).
- Place the sub-soiler in the working position (A).
- Adjust the working depth of the sub-soiler by moving to another attachment point (a).
- Insert the shear bolt (2) and the pivot bolt (1) into the side of the sub-soiler.
- Tighten the screws (observe the correct tightening torque).

Tightening torque - shear bolt

Dimensions	Grade 4.6		Wrench size (DIN ISO 272)
	Nm	lb-ft	
M 16	71	53	24

Tightening torque - fastening bolt

Dimensions	Grade 8.8		Wrench size (DIN ISO 272)
	Nm	lb-ft	
M 16	71	53	24

7.7 Gauge wheel adjustment

i IMPORTANT:
Check the general condition of the wheels daily.

7.7.1 Tyre pressures

i IMPORTANT:
Regularly check the pressure of the tyres. The pressure in the tyres must never be less than the recommended min. tyre pressure.

Tyre size	Working pressure pressure bar / MPa	Maximum speed km/h / mph
600 x 8	4.0 / 0.40	25 / 15

- Follow the manufacturer's recommendations (values marked on the sidewall of the tyres).

! CAUTION:
- An "over-inflated" tyre risks to burst.
- An "under-inflated" tyre risks come off the rim.

7.7.2 Tightening of wheel studs

- The 1st time after 10 hours or 50 km.
- Again after 10 hours or 50 km.
- Check the torque before the start of the season and every 50 hours during use.

7.7.3 Gauge wheel height adjustment

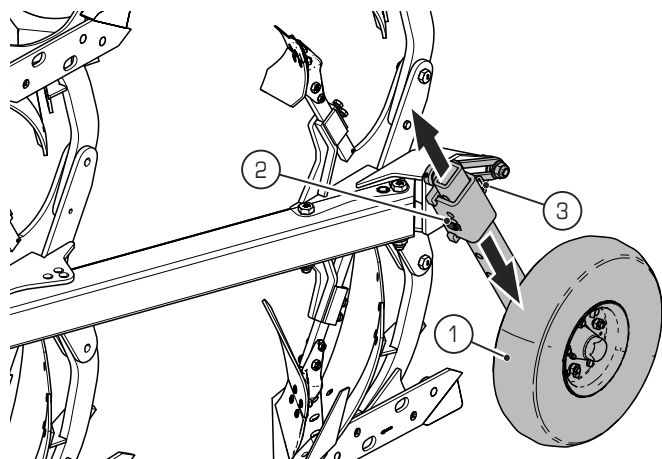

Legend
1 Gauge wheel
2 Lynch pin
3 Clevis pin

Adjust the height of a wheel to control the depth of the rear of the implement.

- Raise the wheel to increase the working depth.
- Lower the wheel to decrease the working depth.

Adjustment

- Remove the safety pin (2).
- Remove the cross pin (3).
- Lower or raise the gauge wheel (1). Once it is at the desired height, refit the cross pin (3) and insert the safety pin in its hole (2).

7.7.4 Gauge wheel turnover speed adjustment

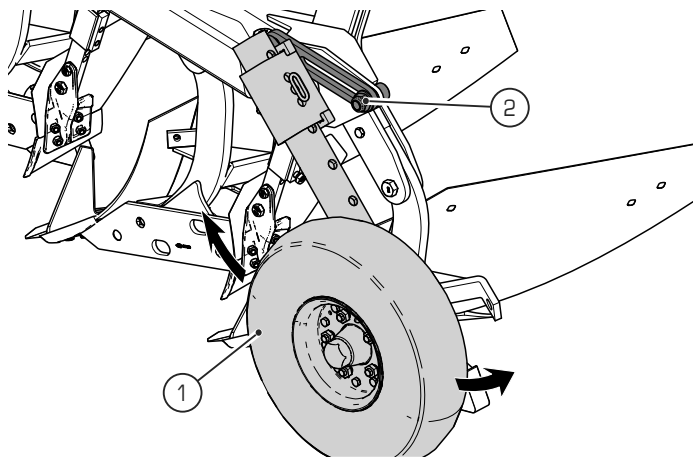

Legend
1 Gauge wheel
2 Locking bolt

The bolt (2) limits the speed of the gauge wheel unit (1) during implement turnover.

Adjustment

- Loosen the bolt (2) to free the strut during turnover.
- Tighten the bolt (2) to reduce the turnover speed.

i IMPORTANT:
Over-tightening the bolt (2) may prevent gauge wheel unit turnover.

8 CHANGING BETWEEN TRANSPORT AND WORKING POSITION



DANGER:

Risk of electric shock.

In the event of contact or insufficient distance between the implement and live high voltage power lines, there is a risk of severe, even fatal injuries
- Never use the implement in the immediate vicinity of live power lines or electrical equipment.
Maintain a minimum safety distance of 6 m from live power lines or electrical equipment.
- Never stand close to the implement when it is used in the vicinity of live power lines or electrical equipment.

Before driving on a public road:

- Place the implement in the transport position.
- Check the operation and cleanliness of the signalling and lighting devices.

8.1 Changing to transport position

Before driving on a public road:

- Raise the implement to its maximum extent.
- If necessary, lower the implement to lower the centre of gravity. Ensure that the height remains sufficient to avoid any risk of contact with the ground.
- Block all the driver's cab control levers (hydraulic control valves, lifting, etc.), to prevent unexpected movement liable to cause an accident.
- Check the operation and cleanliness of the signalling and lighting devices.

8.2 Driving on the road



CAUTION:

Take account of the overhang when driving on the public highway. Risk of accidents involving other road users. Risk of damage to signposts, telephone poles, etc.

Before driving on a public road:

- Ensure that the legally required signalling and lighting devices (lights, reflectors, etc.) are correctly mounted, clean and in good working order.

On public roads, observe the Highway Code:

- The tractor towing the implement must be of the same size, weight and power as that used in the field.
- Do not drive at more than 25 km/h (15 mph).
- Drive at a reasonable speed so that the tractor-implement assembly is always under control.
- Do not drive down a hill faster than the maximum possible speed at which it can be climbed.

- Slow down in the corners, and when the road surface is irregular.
- Do not attempt to take tight corners on the brakes.
- Always check the tightness of wheel studs before heading onto a public road. They may be loose due to vibrations.
- Respect the maximum allowable dimensions (width, length, weight). If the maximum dimensions are exceeded, comply with the regulations in force concerning abnormal loads (escort, abnormal load sign, administrative authorisation).
- Observe the maximum axle load and the maximum authorised gross laden weight. Ensure that the load on the front axle of the tractor is never less than 20% of the tractor dead weight. If necessary, attach counterweights to the front of the tractor.



CAUTION:

When towing the implement on the road, the operator is responsible for the entire tractor/implement(s) train. He is responsible for ensuring compliance with the laws applicable in the country of use (bringing into compliance and monitoring changes in regulations).

8.3 Changing to working position

- Fully lower the implement.
- Adjust the various settings (working width, gauge wheel, etc.) before working.

9 FIELD ADJUSTMENTS

CAUTION:
Read this chapter in its entirety to properly understand all adjustments, the correct order and procedures before starting work.

CAUTION:
Perform only one adjustment at a time.

9.1 Use in the field

- Place the implement in the working position (see § 8.3).

IMPORTANT:
For an optimum result, the working speed must be between 5 and 7 km/h (3 and 4.5 mph). A higher speed may cause rapid wear of the working parts.

- Raise the implement before performing field headland manoeuvres.
- Do not make sharp turns when the implement is in the ground.
- Reduce speed when turning or when clearing obstacles (ditches, bumps, stony patches, etc.).
- Alternate the side of the plot on which ploughing is started, it prevents the soil always being moved to the same side. You will avoid ultimately forming a mound one side of the field and a hollow on the other
- With a new implement or at the beginning of each new season and for best results, it may be necessary to perform several return runs. With each pass, the mould boards are better polished, the soil slides more easily and settings can be refined.

9.2 First pass

For the 1st pass, the tractor is not in the furrow. This may change certain settings, including the inclination and the first plough body adjustment (depth and width of cut).

9.2.1 Ground work

- Drive forwards slowly and lower the implement for a gradual entry of the bodies into the soil.

9.2.2 Alignment adjustment

To adjust the alignment:

- The tractor's stabilisers must be free (see 7.5).
- The top link must be in line behind of the tractor.
 - Top link is too far towards the ploughed side: Tighten the nut on the adjustment screw to align the implement with the draught line of the tractor
 - Top link is too far towards the unploughed side: Loosen the nut on the adjustment screw to align the implement with the draught line of the tractor

9.2.3 Working depth adjustment

The working depth is controlled by:

- The height of the tractor's hydraulic lifting mechanism for the front of the implement.
- The height of the gauge wheel for the rear of the implement.

Adjustment of the tractor's lifting height

For the first pass, adjust the lifting height of the tractor to avoid the creation of an excessive ridge by the 1st mouldboard.

Setting the tractor draught control system

Set the tractor draught control to minimum sensitivity. The working depth of the 1st plough body will be constant. Once adjustment is completed, increase the sensitivity to optimise the tractor's grip.

IMPORTANT:
Under adverse conditions (sodden ground, tractor power limit, etc.) it is not possible to work with the draught control set to minimum sensitivity. In this case, account should be taken of lifting mechanism reactions to estimate the average depth..

Wheel height adjustment

The height of the gauge wheel can be adjusted at the first pass. Checking and/or a final adjustment will be made during subsequent passes (See § 7.6).

9.3 Second pass

Before finalising the settings, make sure that the mouldboards are polished and soil slides without sticking, otherwise clean them.

In sticky soil, when using for the first time, remove the points, this can accelerate the scouring of the mouldboards.

9.3.1 Alignment adjustment

The alignment is correctly set when

- The implement is in line behind the tractor.
- The top link must be in the axis of the tractor.
- The landsides should not apply unnecessary force to the ploughing face.

Otherwise, re-adjust the alignment of the implement.

9.3.2 Longitudinal levelling

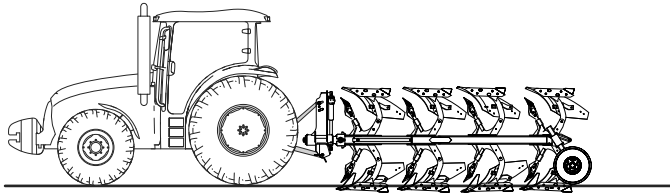

The 2nd pass is made with the tractor in the furrow. The machine must be level so that all the bodies work at the same depth.

Adjustments

- Find a balance between:
 - The lift height of the tractor.
 - The height of the gauge wheel.
 - The length of the top link.
- The position of the top link:
 - When working, the top link must be at a higher level on the implement side than the tractor side, which ensures good load transfer to the front of the tractor. It must be ensured that: $X < Y$ (see diagram). Choose the appropriate hitch hole or move the height of the top link yoke on the tractor.
- Length of the top link:
 - When working, the length of the top link must be adjusted, so that the clevis pin is centred.
 - The top link does not affect the levelling of the implement and the operation of tractor draught control.
- Adjustment of the wheel working depth will give rise to:
 - An adjustment of the tractor's lift height.
 - Checking the length of the top link.
 - Adjustment of the inclination on the next pass, if required.

9.3.3 Lateral levelling

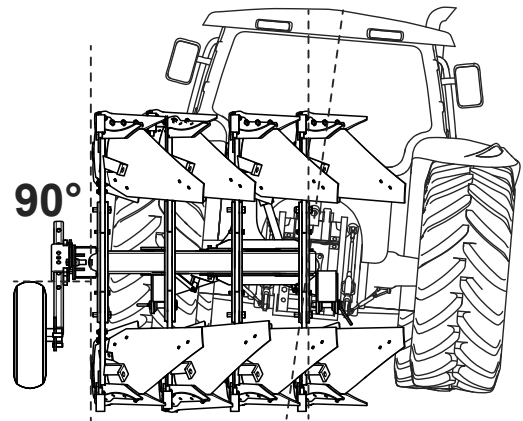

The 2nd pass is made with the tractor in the furrow. The implement must be levelled in the lateral (left-to-right) direction.

On sloping or very clayey ground, tilt the implement to the ploughing side to increase the pressure at the rear the mouldboards on the soil.

Adjustments

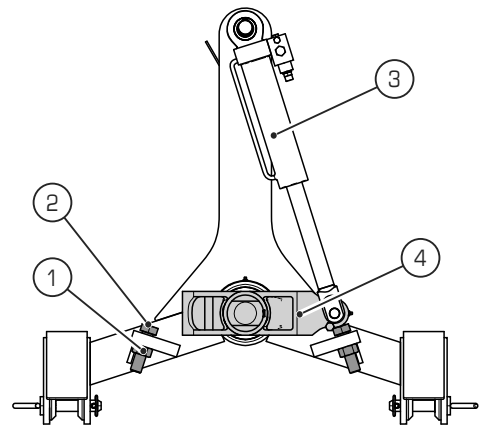

Legend

- 1 Lock nut
- 2 Adjusting screw
- 3 Turnover cylinder
- 4 Stub axle

i IMPORTANT:
The inclination adjustment must be performed separately on each side of the implement.

- Raise the implement off the ground.
- Remove the load exerted on the vertical alignment end stops by operating the turnover cylinder (3).
- Loosen the lock nut (1).
- Tighten or loosen the adjusting screw (2) as required.
- Re-tighten the lock nut (1).
- Return the implement to the working position, then place it in the ground.
- Check the inclination adjustment (the elements should be perpendicular to the ground).
- If the adjustment is not correct, repeat the operation.

9.4 Adjustment of skimmers (optional)

9.4.1 Skimmer - Adjusting working depth

Setting instructions

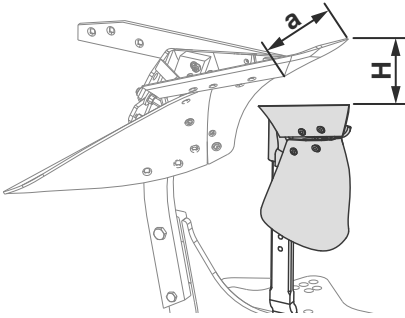

- From the distance to the ploughshare edge (H) resulting in the work depth of the Vari-Fix.
- H = Factory setting approx. 18 cm
- Set H in such a way that the blade (a) works in the soil over the entire width.
- Ensure that all the skimmers have the same adjustment.

Adjustment - Vari-Fix

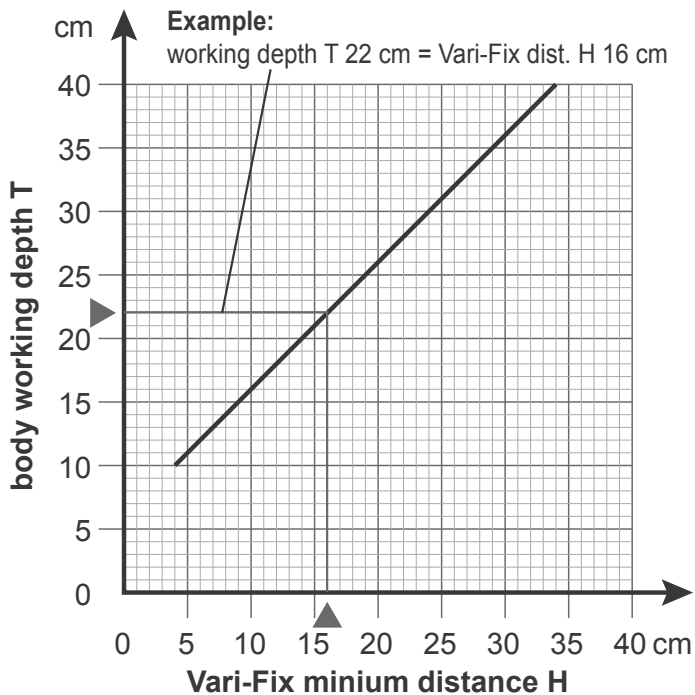
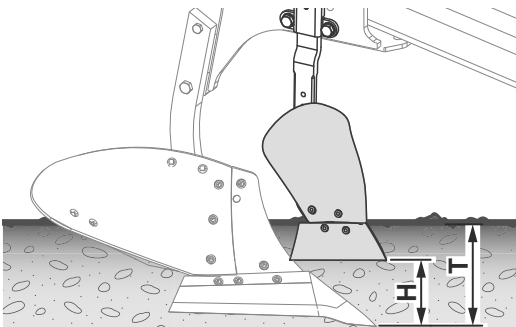

- Calculate distance (H) using the chart above.

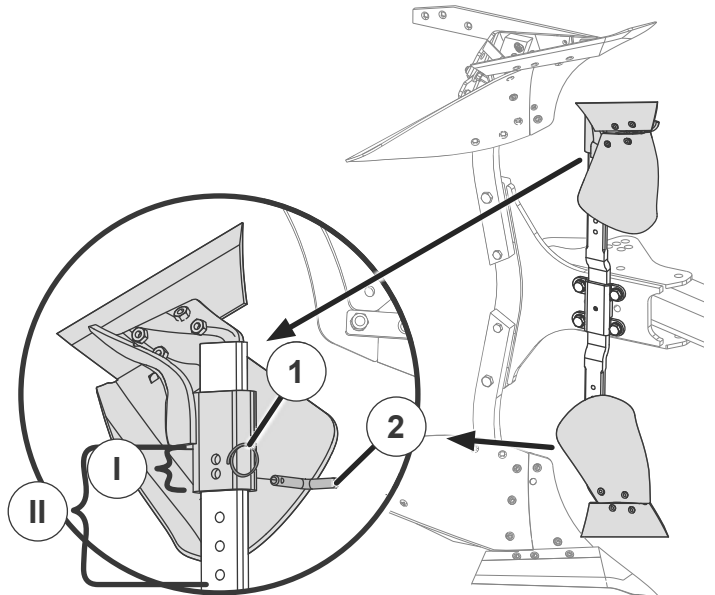

Legend

- 1 Safety ring
- 2 Self-locking bolt

- Remove the safety ring (1).
- Pull the self-locking bolt and set the working depth by adapting the hole in the leg (I) to the hole of the support (II).
- Insert the self-locking bolts (2) into the corresponding hole and block with the safety ring (1).
- Set all the skimmers to the same working depth.

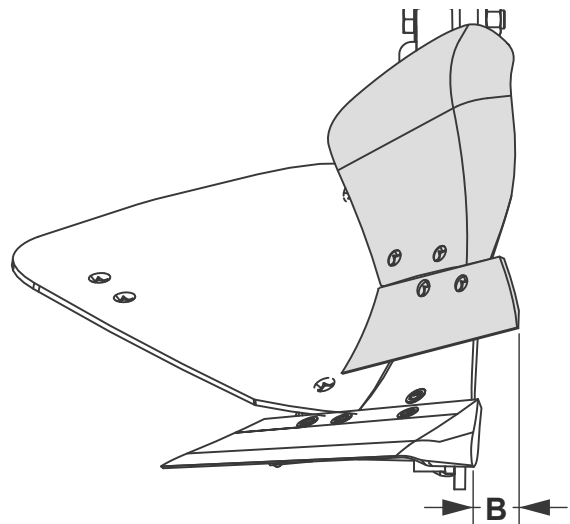

COMMENT:

B = Factory lateral overlap setting approx. 2 - 3 cm.

9.5 Adjustment of deflector (optional)

Adjustment tips

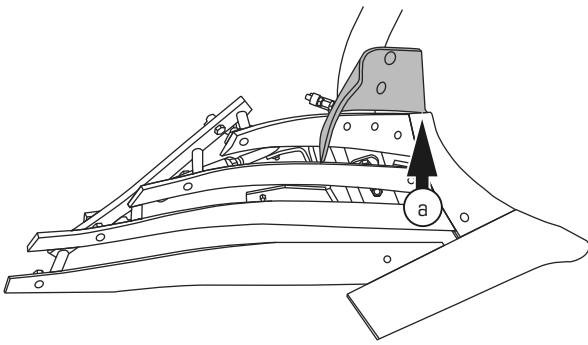

- Set the depth of the deflectors so as not to hold back the soil when working.
- In ground with clods to be broken, the mould boards are supposed to only skim over the tops of the ridges. Adapt the working depth to the speed of the implement.
- The front of the mould board (a) must rest on the scraper.

Adjustment

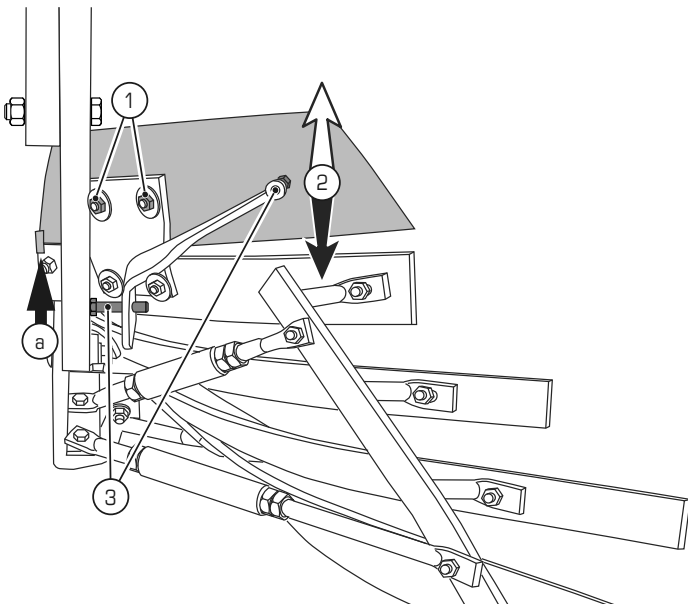

Legend

- 1 Fastening screw
- 2 Support
- 3 Retaining screw

- Loosen the fastening screw (1).
- Set the height of the mould boards in the oblong holes of the support (2).
- Tighten the fastening screws (1) (observe the correct tightening torque).
- Adjust the retaining screws (3).

Tightening torque

Dimensions	Grade 8.8		Wrench size (DIN ISO 272)
	Nm	lb-ft	
M 12	137	101	19

9.6 Adjusting the sub-soiler (optional)

Adjustment tips

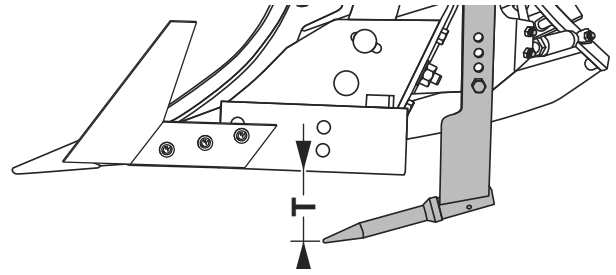

- Working depth
T) approx. 13.5 cm to approx. 21.5 cm in 3 cm steps

Adjustment

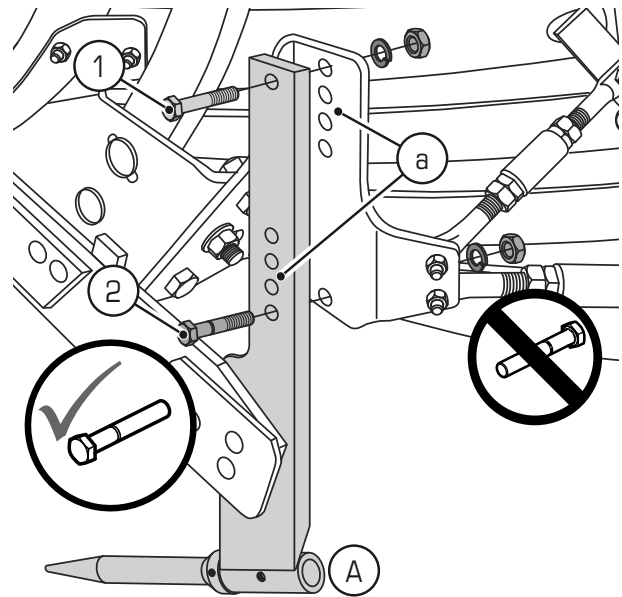

Legend

- 1 Pivot bolt
- 2 Shear bolt

- Remove the pivot bolt (1) and the shear bolt (2).
- Adjust the working depth of the sub-soiler by moving to another attachment point (a).
- Insert the pivot bolt (1) from the sub-soiler side.
- Insert the shear bolt (2) from the sub-soiler side.
- Tighten the fastening screws (observe the correct tightening torque).



COMMENT:

Take care to correctly position the shear bolt.

Tightening torque - shear bolt

Dimensions	Grade 4.6		Wrench size (DIN ISO 272)
	Nm	lb-ft	
M 16	71	53	24

Tightening torque - fastening bolt

Dimensions	Grade 8.8		Wrench size (DIN ISO 272)
	Nm	lb-ft	
M 16	230	170	24

MAINTENANCE



CAUTION:

Observe the safety instructions (Chapter 2) before starting service work or replacing spare parts.

- The operator and the owner are responsible for the implement's maintenance.
- Before commencing any work on the implement, switch off the engine and remove the tractor's ignition key.
- Risk of trapping or crushing injuries during maintenance or cleaning.
- Stabilise the implement before performing any maintenance or cleaning operations.
- Make sure that the implement cannot be inadvertently operated while carrying out maintenance or cleaning work.



CAUTION:

Make sure that your safety is assured by the techniques used to raise the implement.



CAUTION:

Tyres must be fitted and removed by qualified personnel.



IMPORTANT:

The operator and the owner of the implement must not under any circumstances tamper with or adjust sealed components.

10 PROTECTION OF THE ENVIRONMENT

10.1 Soil contamination



IMPORTANT:

Take care not to spread waste grease and substances such as hydraulic oil on the ground or to dispose of them in the drains.



IMPORTANT:

Collect the drained hydraulic oil in sealed, clean and containers provided for this purpose.

10.2 Worn tyres



CAUTION:

It is prohibited to store, abandon, deposit tyres in the environment or to burn them in the open air. Take them to an approved dealer or collection point.

11 CLEANING

Clean the implement.

- When cleaning with a high pressure cleaner, do not direct the jet at joints, bearings etc. or at electrical components.

- Pay special attention to safety stickers affixed to the implement. Damaged or detached stickers must be replaced.
- Do not use compressed air to clean hydraulic components.
- Perform complete lubrication of the implement after each cleaning.

12 INSPECTION



IMPORTANT:

Inspect implement after each use and perform the required repairs.

- Check the general state of the implement :
 - The welds.
 - The wheels, tyres and the wheel studs.
 - The bolts of wearing parts under stony conditions (strong vibrations).

12.1 Checking the hydraulic system



CAUTION:

NEVER place a hand over escaping hydraulic fluid. Leaks must be located with a tool. Risk of injury or infection due to hydraulic fluid. Hydraulic fluids escaping under high pressure are able to penetrate the skin and cause serious, even fatal injuries.



CAUTION:

Your implement may be equipped with hydraulic accumulators. These are pressurised and it is dangerous and prohibited to remove the accumulators or their piping. This operation may only be performed by qualified personnel (consult your dealer).



CAUTION:

Before working on the hydraulic circuit, set the implement down on the ground and depressurise the hydraulic circuit.



CAUTION:

Never heat, weld, saw, grind or flame cut close to hydraulic circuits or components or any other flammable parts. For welding work on the implement, disconnect the tractor battery and protect the hydraulic circuits so that they are not damaged by welding sparks and spatter.

- Check hydraulic hoses for wear (deterioration of the external sheath, wear etc.).
- Check that couplings, components, etc. are securely tightened.

MAINTENANCE FITIS 120 M

- Drain the implement if you need to replace components in the hydraulic circuit.



CAUTION:

Never open, pierce, weld or perform work on the hydraulic accumulators.



IMPORTANT:

Replace hydraulic hoses with others having the same technical specifications.



IMPORTANT:

Collect hydraulic oil, hydraulic accumulators, tyres and take them to a dealer or an approved collection point. Do not abandon them in the environment.

12.2 Lubrication and greasing

Location of lubricating nipples



IMPORTANT:

The location of lubrication nipples depends on the various assemblies and options of your implement.



IMPORTANT:

Check the location of lubrication nipples using the spare parts catalogue supplied with your implement.

Example: 4-furrow Prima

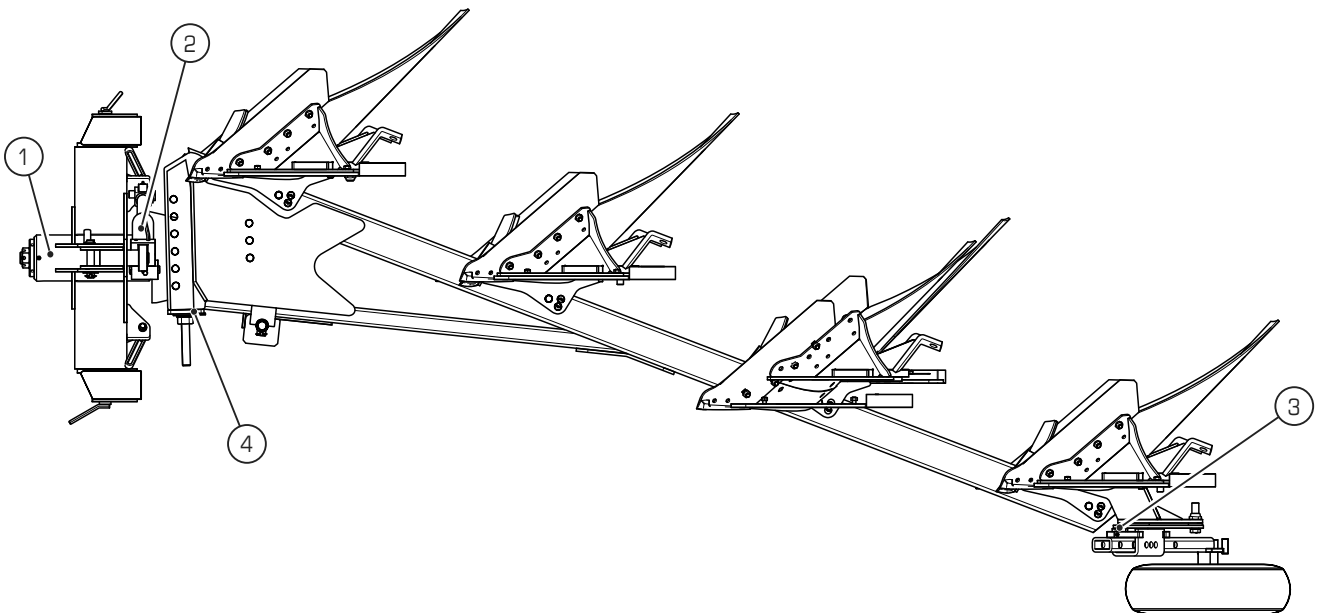

Legend

- 1 Lubrication nipples on turnover axle
- 2 Lubrication nipples on turnover cylinder
- 3 Lubricating nipples on rear gauge wheel
- 4 Lubricating nipples on sub axle

Regular lubrication of all moving parts ensures optimum implement operation and prolongs service life.

The lubricating nipples on the pivot points enable lubrication of the axles.

Before lubrication, clean the lubricating nipples. Impurities can cause blockage of the lubrication duct. If a lubricating nipple is clogged, worn or missing, dismantle it for cleaning or replace it.

Check that the grease can flow.

Take care not to apply excessive grease. An excess of grease will form an abrasive paste when it comes into contact with dust. Remove and wipe away any spillage or build-up of grease.

- Under normal working conditions, grease every 25 working hours.
- Under severe or intensive conditions, grease more frequently.

13 TROUBLESHOOTING AND REPAIR

13.1 Tripping the mechanical stone safety device - replacing the shear bolt

Each plough body is equipped with a shear bolt. When one of the bodies of the implement meets an obstruction, the mechanical stone safety device is tripped by shearing of the shear bolt. The plough body is folded back:



DANGER:

Risk of injury due to heavy components and sharp edges. Gloves must be worn. Risk of accidents when performing repairs. Do not work under unprotected raised implements. Prevent the implement from lowering.

When the stone safety device is tripped:

- Immediately stop the tractor.
- Switch off the tractor engine and immobilise it.
- Prevent start-up of the tractor (remove the key from the ignition).

13.2 Replacing the shear bolt

Repair instructions:

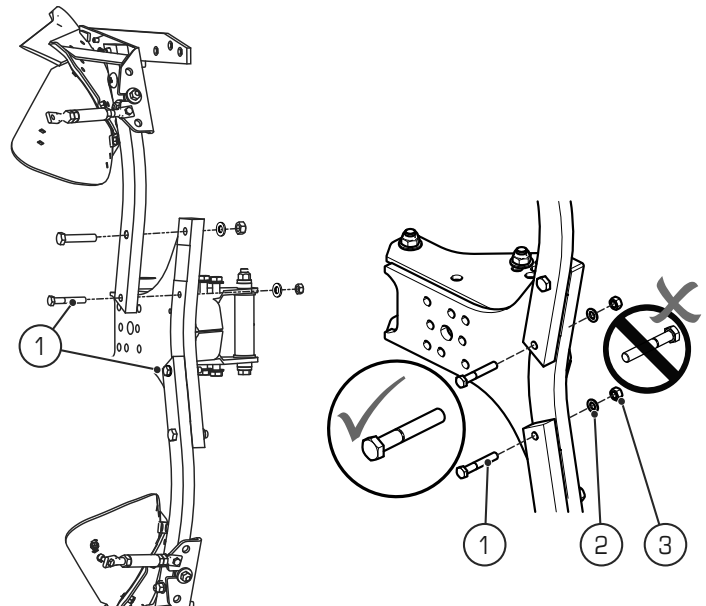

Legend

- 1 Shear bolt x1**
- 2 Washer x1**
- 3 Nut x1**

- *The number of washers may differ. Beware of working conditions on site.
- Systematically insert the shear bolt (2) from the link arm side.
- Always use the original shear bolts.
- Replace damaged bolts with OEM bolts.
- The plough body must be pointing downwards.
- Only approach the plough body from the rear.

Repair :



CAUTION:

Risk of accidents when loosening the the pivot bolt.
Risk of accidents when plough body swings back.
Only approach the plough body from the rear. Use a

special RABE tool.

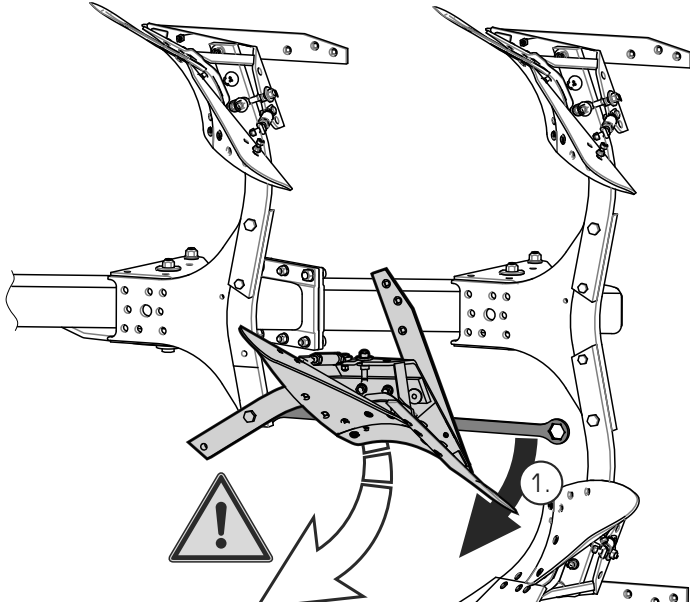
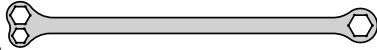

- Loosen the nut of the pivot bolt .

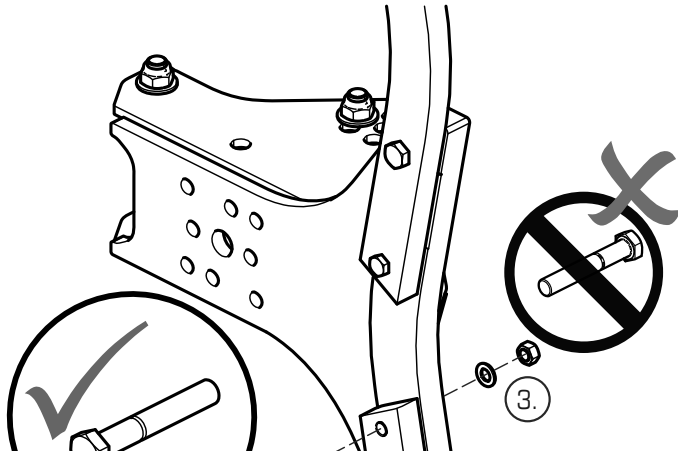

- Insert the new shear bolt from the link arm side.
- Place the washer and tighten the fastening nut.
- Block the shear bolt and the pivot bolt (observe the tightening torque).

Tightening torque - shear bolt

Link arm dimensions	Shear bolt		
	Dimensions	Bolt strength	Tightening torque
60 x 30	M16 x 1.5 x 90	8,8	190 Nm 140 lb-ft
70 x 30	M16 x 1.5 x 100	10,9	225 Nm 166 lb-ft
70 x 35	M16 x 1.5 x 100	12,9	315 Nm 232 lb-ft
80 x 35	M20 x 1.5 x 120	12,9	385 Nm 284 lb-ft

Tightening torques - pivot bolt

Link arm dimensions	Pivot bolt		
	Dimensions	Bolt strength	Tightening torque
60 x 30	M16 x 1.5 x 90	12,9	315 Nm 232 lb-ft
70 x 30	M20 x 1.5 x 100	10,9	460 Nm 339 lb-ft
70 x 35	M20 x 1.5 x 100	12,9	640 Nm 472 lb-ft
80 x 35	M24 x 1.5 x 110	10,9	780 Nm 575 lb-ft

13.2.1 Replacing the sub-soiler shear bolt (optional)

Attachment

- 1 x M16 mm shear bolt
- 1 x retaining ring
- 1 x M16 mm nut

Repair tips

Repair instructions:

- Systematically insert the shear bolt from the sub-soiler side.
- Use the original shear bolts.
- Replace damaged bolts with OEM bolts.

Repair

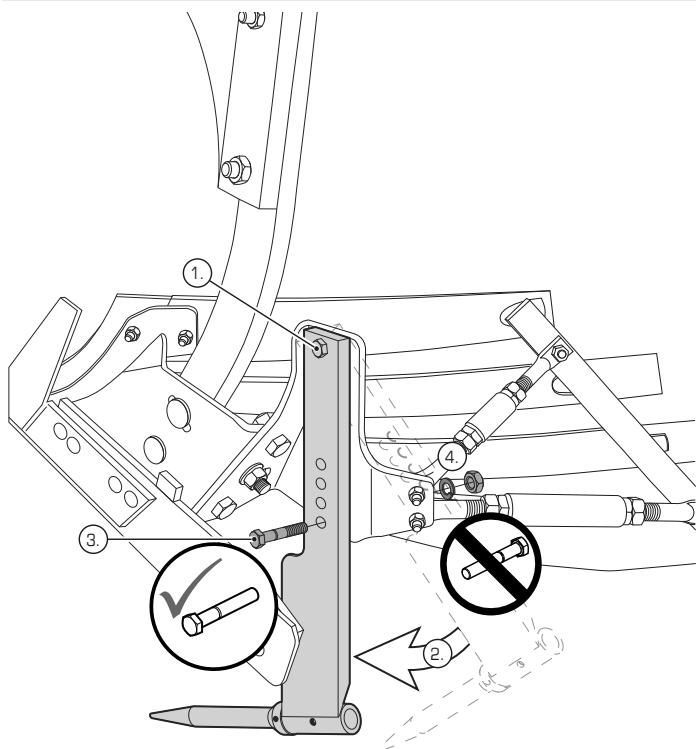

- Legend**
1 Pivot bolt
2 Shear bolt

- Loosen the pivot bolt (1). **Swing the sub-soiler into the retracted position.**
- Insert the new shear bolts (2) from the sub-soiler side.
- Place the washer and tighten the fastening nut.
- Block the shear bolt and the pivot bolt (observe the tightening torque).

Tightening torque - shear bolt

Dimensions	Grade 4.6		Wrench size (DIN ISO 272)
	Nm	lb-ft	
M 16	71	53	24

Tightening torque - Pivot bolt

Dimensions	Grade 8.8		Wrench size (DIN ISO 272)
	Nm	lb-ft	
M 16	230	170	24

14 SPARE PARTS

In order to ensure the reliable operation and long service life of your implement, only use original spare parts from the manufacturer. The use of any parts, other than those provided by the manufacturer automatically voids the warranty.

i IMPORTANT:
This implement carries a CE conformity mark. Use only new original replacement parts approved by the manufacturer.

- Ensure that replacement parts are correctly installed and positioned in the right direction. Check the implement each time a part is installed and after each maintenance operation to check correct operation.

14.1 Maintenance of plough bodies

i IMPORTANT:
Protect the working surfaces of the mould boards and the shares against corrosion by applying a light coating of grease or oil.

- In particularly sticky soil conditions, apply a coat of liquid oil with a sprayer or from an aerosol can on the mould boards as soon as you leave the field.
- When placing in storage, applying a thicker coat of oil to the mould boards or spraying with dry graphite will slow down corrosion.

14.2 Tightening torques

- Observe the tightening torques of the components. For each component, the torques vary depending on the surface condition and the lubrication. All values in the table below are for information only.

Dimensions		Category 8.8			Category 10.9			Category 12.9			
Ø (mm)		N x m	kg x m	lb - ft	N x m	kg x m	lb - ft	N x m	kg x m	lb - ft	
M6		10	11.1	1.13	8.19	16.3	1.66	12.02	19.1	1.94	14.09
M8	13		27	2.75	19.92	39	3.97	28.78	46	4.69	33.94
M10	17	16	53	5.40	39.11	78	7.95	57.56	92	9.38	67.89
M12	19	18	92	9.38	67.89	136	13.87	100.36	159	16.21	117.34
M14	22	21	148	15.09	109.22	218	22.23	160.88	255	26.01	188.19
M16	24		232	24	171.21	341	34.78	251.65	399	40.69	294.46
M18	27	26	330	23.66	243.54	469	47.83	346.12	549	55.99	405.16
M20	30		471	48.04	347.59	667	68.03	492.24	781	79.66	576.37
M22	32	34	648	66.09	478.22	920	93.84	678.96	1077	109.85	794.82
M24	36		809	82.51	597.04	1148	117.09	847.22	1343	136.98	991.13
M27	41		1201	122.50	886.33	1706	174.01	1259.02	1997	203.69	1473.78
M30	46		1628	166.05	1201.46	2311	235.72	1705.51	2704	275.80	1995.55
M33		50	2216	226.03	1635.40	3148	321.09	2323.22	3684	375.76	2718.79
M36	55		2840	289.68	2095.92	4036	411.67	2978.56	4723	481.74	3485.57

1 Nm x m = 0.102 kg x m

1 Nm x m = 0.738 lb x ft

1 kg x m = 9.81 N x m

1 lb x ft = 1.355 N x m

14.3 Precautions for storage



CAUTION:

Never allow children to play around an implement if it is hitched to a tractor or in its storage area.



DANGER:

Never store agricultural machinery under a power line.

- Before unhitching implement for storage, make sure the
- storage area is level, clean and firm. Preferably store the implement in a dry and dust-free shelter.
- Use the parking support legs and other locking devices to prevent the implement moving during or after unhitching.
- Place chocks under the wheels.
- Store the implement in the working position.
- Never leave the implement in the transport position.
- Depressurise the hydraulic circuits by operating the tractor control levers (tractor engine switched off).
- Store the implement away from human activity.
- Store the implement in a dry, clean place. Retract or grease the cylinder rods to prevent corrosion.
- The wheels are able to turn freely. Do not store or rest anything on them.

14.3.1 Placing the sub-soiler in the rest position

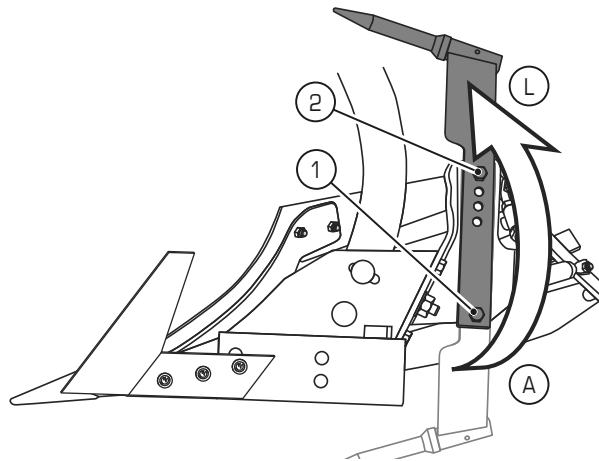

Legend

1 Shear bolt

2 Pivot bolt

Before storing, move the sub-soiler from the working position (A) to the rest position (L).

Assembly

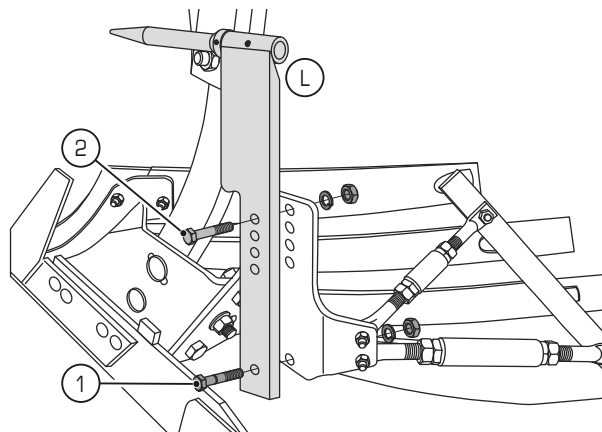

Legend

- 1 Shear bolt
- 2 Pivot bolt

- Remove the shear bolt (1) and the pivot bolt (2).
- Place the sub-soiler in the storage position (L).
- Refit the shear bolt (1) and the pivot bolt (2).
- Tighten the bolts.

14.4 Returning to operation and additional check

- After storage and before use, perform a full visual inspection (corrosion, hydraulic lines, tyre inflation, etc.) of the implement.
- After the visual inspection, hitch the implement to a tractor and test its operation.

15 CE DECLARATION



EC declaration of conformity in accordance with the EC-Directive 2006/42/EC, Appendix II A

Declared herewith by the manufacturer

Grégoire-Besson GmbH
Am Rabenwerk 1
49152 Bad Essen

that the following product

Designation: Mounted reversible plough (Anbau-Drehpflug)

Type: Fitis 120 M

Serial no.:

fulfils all essential provisions of the directive regarding machines (2006/42/EC) including the changes applicable at the time this declaration was prepared.

The machine also fulfils the provisions of the following EC directives, with the changes applicable at the time this declaration was prepared:

EN ISO 4254-1:2009 Agricultural machinery - Safety - Part 1: general requirements

EN ISO 12100:2010 Safety of machinery - Basic concepts, general design principles

This declaration relates exclusively to machinery in the state in which it was placed on the market. Subsequent changes or subsequently added components are not taken into account and make the declaration no longer applicable or valid.

Person authorised to compile documentation

Grégoire-Besson GmbH
Am Rabenwerk 1
49152 Bad Essen

Signatory

Issued in: Bad Essen
Name of the signatory: Patrick Besson
Business function: General Manager

Issued on:

Signature:



GRÉGOIRE-BESSON FRANCE

49230 Montfaucon / Montigné-sur-Moine
FRANCE

Tél. (+33) 2 41 64 72 67
Fax (+33) 2 41 64 67 73
contactfr@gregoirebesson.fr
fr.gregoire-besson.com

GRÉGOIRE-BESSON UK LIMITED

Spalding Road - Bourne - Lincs. PE10 0AU.
UNITED KINGDOM

Phone : +441778423787
Fax : +441778394431
enquiries@gregoire-besson.co.uk
gregoire-besson.co.uk

GRÉGOIRE-BESSON GMBH

Am Rabewerk 1 - 49152 Bad Essen
DEUTSCHLAND

Tel. (0 54 72) 771 - 0
Fax. (0 54 72) 771 - 195
contactfr@gregoirebesson.fr
fr.gregoire-besson.com/de

GRÉGOIRE-BESSON CANADA INC

4480, Rue Martineau - St Hyacinthe (P. Québec) - J2R 1V1
CANADA

Tel : (1) 450 799 56 15
Fax : (1) 450 799 56 29
info@gregoirebesson.ca
ca.gregoire-besson.com

GRÉGOIRE-BESSON POLSKA Sp.zo.o.

Kowanówko | ul. Obornicka 1a - 64-600 Oborniki
POLSKA

tel : 61 297 75 30
fax : 61 297 22 62
gbesson@poczta.onet.pl
pl.gregoire-besson.com

ООО «ГРЕГУАР-БЕССОН ВОСТОК»

308006, г.Белгород, ул. Корочанская 132 А,
RUSSIA

тел. : +7 (4722) 402-210
факс : +7 (4722) 402-210
info@gbvostok.ru
ru.gregoire-besson.com

ТОВ «ГРЕГУАР-БЕССОН УКРАЇНА»

18028, Україна, Черкаська обл., м. Черкаси, вул. Рози
Люксембург, буд. 202.
UKRAINE

тел. : + 38 (0472) 71-28-23
факс : + 38 (0472) 71-28-23
gregoirebesson.ua@yandex.ua
ru.gregoire-besson.com

GRÉGOIRE-BESSON CHINE

法国格力格-贝松公司 北京代表处 | 100025北京市朝阳区延
静里中街3号长信大厦220室
CHINA

电话 : 0086-10-65 08 06 40
传真 : 0086-10-65 08 06 41

cn.gregoire-besson.com